

INDEX OF DRAWINGS

- A1 Cover and Index
- A2 Schedules and Notes
- A3 Spec Notes, Code Summary
- A4 Bldg. H Overall First Floor Plan
- A5 Bldg. H Overall Second Floor Plan
- A6 Bldg. H Enlarged First Floor Plan Units 1, 2, 3
- A7 Bldg. H Enlarged First Floor Plan Unit 4
- A8 Bldg. H Enlarged Second Floor Plan
- A9 Bldg. H Roof Plan
- A10 Bldg. H East and South Elevations
- A11 Bldg. H West and North Elevations
- A12 Bldg. H Building Section A--A
- A13 Bldg. H Building Section B--B
- A14 Bldg. H Building Section C--C
- A15 Bldg. H Building Section D--D
- A16 Bldg. H Building Section E--E
- A17 Details
- A18 Details
- A19 Details

- S1 Structural General Notes
- S2 Bldg. H Foundation Plan
- S3 Bldg. H First Floor Shear Wall Plan
- S4 Bldg. H Second Floor Shear Wall Plan
- S5 Bldg. H First Floor Framing Plan
- S6 Bldg. H Second Floor/Low Roof Framing Plan
- S7 Bldg. H High Roof Framing Plan
- S8 Details
- S9 Details

baxter fourplexes

PHASE II
BUILDING H

Owner/Contractor:
Cook Inlet Housing Authority
3510 Spenard Rd., Suite 100
Anchorage, AK 99503

Structural Engineer:
LDR Engineering Services, Inc.
L.D. "Randy" Randolph
(907) 227-0028

Designer:
FRamE
Clark Yerrington
(907) 351-4805

APPLICABLE CODES
2018 IRC and 2018 IBC with
Municipal amendments.

GENERAL NOTES

1. Notify Designer of any errors or discrepancies in the documents.
2. Keep the job site clean and safe. Install temporary railings at level changes.
3. Provide a portable toilet for use during construction.
4. Consult Subcontractors to identify additional work items not specifically described herein.
5. At walls greater than 10'-0" height, provide fire blocking at 10'-0" maximum spacing.

COOK INLET HOUSING AUTHORITY
BAXTER MULTIPLEXES, PHASE II
Tract B, valetskaya Addition No. 1
NHN Erna Court
ANCHORAGE, ALASKA

DR. BY: CLARK
DATE: 23 JAN 26

DOOR SCHEDULE
3-BR END UNIT [H1]

	width	height	type	material	finish	hardware	glazing	notes
100	2'-8"	6'-8"	exterior	fiberglass	paint	lockset/dbolt	none	1
101	2'-8"	6'-8"	exterior	fiberglass	paint	lockset/dbolt	none	1
102	3'-0"	6'-8"	exterior	fiberglass	paint	lockset/dbolt	none	1, 5
103	2'-8"	6'-8"	exterior	fiberglass	paint	lockset/dbolt	safety	1, 6
104	2'-8"	6'-8"	one pnl.	wood	clear	latchset	none	---
105	2'-8"	6'-8"	one pnl.	wood	clear	privacy lock	none	2
106	2'-8"	6'-8"	one pnl.	wood	clear	trolley trk./pull	none	---
107	4'-0"	6'-8"	one pnl.	wood	clear	latchset	none	---
108	[NOT USED]							
109	[NOT USED]							
201	2'-8"	6'-8"	one pnl.	wood	clear	privacy lock	none	---
202	2'-8"	6'-8"	one pnl.	wood	clear	privacy lock	none	---
203	2'-8"	6'-8"	one pnl.	wood	clear	privacy lock	none	---
204	2'-4"	6'-8"	one pnl.	wood	clear	privacy lock	none	2
205	2'-4"	6'-8"	one pnl.	wood	clear	latchset	none	---
206	2'-4"	6'-8"	one pnl.	wood	clear	latchset	none	---
207	5'-0"	6'-8"	one pnl.	wood	clear	track and pulls	none	---
208	5'-0"	6'-8"	one pnl.	wood	clear	track and pulls	none	---
209	[NOT USED]							

2-BR UNIT [H2, H3]

110	2'-8"	6'-8"	exterior	fiberglass	paint	lockset/dbolt	none	1
111	3'-0"	6'-8"	exterior	fiberglass	paint	lockset/dbolt	none	1, 5
112	2'-8"	6'-8"	exterior	fiberglass	paint	lockset/dbolt	safety	1, 6
114	2'-4"	6'-8"	one pnl.	wood	clear	privacy lock	none	2
115	2'-8"	6'-8"	one pnl.	wood	clear	trolley trk./pull	none	---
116	2'-0"	6'-8"	one pnl.	wood	clear	latchset	none	---
117	[NOT USED]							
210	2'-8"	6'-8"	one pnl.	wood	clear	privacy lock	none	---
211	2'-8"	6'-8"	one pnl.	wood	clear	privacy lock	none	---
212	2'-4"	6'-8"	one pnl.	wood	clear	privacy lock	none	2
214	2'-4"	6'-8"	one pnl.	wood	clear	latchset	none	---
215	3'-0"	6'-8"	one pnl.	wood	clear	latchset	none	---
216	1'-6"	6'-8"	one pnl.	wood	clear	latchset	none	---
217	5'-0"	6'-8"	one pnl.	wood	clear	track and pulls	none	---
218	[NOT USED]							
219	[NOT USED]							

DOOR SCHEDULE
2-BR ACCESSIBLE UNIT [H4]

141	2'-8"	6'-8"	exterior	fiberglass	paint	lockset/dbolt	none	1
142	3'-0"	6'-8"	exterior	fiberglass	paint	lockset/dbolt	none	1, 5
143	3'-0"	6'-8"	exterior	fiberglass	paint	lockset/dbolt	none	1
144	3'-0"	6'-8"	one pnl.	wood	clear	privacy lock	none	---
145	2'-8"	6'-8"	one pnl.	wood	clear	privacy lock	none	---
146	3'-0"	6'-8"	one pnl.	wood	clear	privacy lock	none	2
147	3'-0"	6'-8"	one pnl.	wood	clear	latchset	none	---
148	1'-6"	6'-8"	one pnl.	wood	clear	latchset	none	---
149	5'-0"	6'-8"	one pnl.	wood	clear	latchset	none	---
150	5'-0"	6'-8"	one pnl.	wood	clear	track and pulls	none	---
151	3'-0"	6'-8"	one pnl.	wood	clear	trolley trk./pull	none	---

ROOM FINISH SCHEDULE NOTES

- Walls and ceilings shall be painted gypsum board, typical.
- Substitute cementitious tile backer board for gypsum board at kitchen/laundry backsplash walls and tub/showers where ceramic wall tile occurs [if applicable].

WINDOW SCHEDULE GENERAL NOTES

- Sizes in Window Schedule are rough openings. Confirm frame size required with manufacturer, to allow for required insulation and shim space.
- "Normal" head height is aligned with adjacent tops of doors, +/- 6'-10" rough opening height (confirm).

WINDOW SCHEDULE NOTES

- Vinyl frame windows shall be high quality residential grade with insulated double glazing, low E and argon. Frame color white. Provide screens at operating windows.
- Meet all applicable requirements for sleeping room egress, including min. 5.7 square feet net clear opening area; 24 inch min. net clear height; 20 inch min. net clear width (R310.2.1); max. 44 inch sill height (R310.2.2) and operating hardware complying with R310.1.1.
- Translucent or patterned glass for privacy.

DOOR SCHEDULE NOTES

- Weatherstripping and threshold.
- Polished nickel hardware finish at bathroom side for bathroom use.
- Door bottom gasket: brush seal at head and jambs; furnished will all necessary hardware and accessories including track, spring or other counterbalance mechanism, opener, sensors, wall button, remotes, key lock. Thermacore, model 495 with flush wood grain panel finish, manufactured by Overhead Door, color as selected -- or approved substitution.
- 20-minute rated door/frame with weatherstripping, smoke/vapor seal, threshold and closer.
- Entry door in wood frame with integral full-height safety glass side lite as shown on Floor Plans. Confirm rough opening required. Flush panel door and plain rectangular side lite.
- Full safety glass lite.

WINDOW SCHEDULE
BUILDING H

	width	height	head ht.	operation	frame	glazing
	width notes					
A	3'-0"	5'-0"	normal	single-hung	vinyl	clear safety 1
B	3'-0"	5'-0"	normal	single-hung	vinyl	clear 1
C	5'-0"	4'-0"	normal	fixed	vinyl	clear 1
D	3'-0"	4'-0"	normal	single-hung	vinyl	clear 1
E	2'-0"	4'-0"	normal	fixed	vinyl	clear safety 1, 3
F	6'-0"	4'-0"	normal	horiz slider	vinyl	clear 1, 2
G	4'-0"	2'-0"	normal	fixed	vinyl	clear safety 1, 3
H	6'-0"	4'-0"	normal	horiz slider	vinyl	clear 1, 2
J	6'-0"	5'-0"	normal	fixed	vinyl	clear 1
K	3'-0"	4'-0"	normal	single-hung	vinyl	clear 1
L	3'-0"	4'-0"	normal	single-hung	vinyl	clear 1
M	3'-0"	4'-0"	normal	single-hung	vinyl	clear 1
N	3'-0"	5'-0"	normal	single-hung	vinyl	clear safety 1
P	3'-0"	5'-0"	normal	single-hung	vinyl	clear 1
R	3'-0"	5'-0"	normal	single-hung	vinyl	clear 1
S	4'-0"	4'-0"	normal	horiz slider	vinyl	clear 1, 2
T	5'-0"	4'-0"	normal	fixed	vinyl	clear 1
U	5'-0"	4'-0"	normal	fixed	vinyl	clear 1
V	4'-0"	4'-0"	normal	horiz slider	vinyl	clear 1, 2
W	5'-0"	4'-0"	normal	horiz. slider	vinyl	clear 1, 2
X	5'-0"	2'-0"	normal	fixed	vinyl	clear 1
Y	5'-0"	4'-0"	normal	horiz slider	vinyl	clear 1, 2
Z	3'-0"	4'-0"	normal	fixed	vinyl	clear 1
AA	5'-0"	4'-0"	normal	fixed	vinyl	clear 1
BB	5'-0"	4'-0"	normal	horiz. slider	vinyl	clear 1, 2
CC	3'-0"	4'-0"	normal	single-hung	vinyl	clear 1, 3
DD	5'-0"	4'-0"	normal	horiz. slider	vinyl	clear 1, 2
EE	5'-0"	4'-0"	normal	fixed	vinyl	clear 1
FF	6'-0"	4'-0"	normal	horiz. slider	vinyl	clear 1, 2
GG	6'-0"	4'-0"	normal	horiz. slider	vinyl	clear 1, 2

AREA SUMMARY

UNIT H1 -- 3-BR 2-BA		
FIRST FLOOR -- LIV. AREA	564	SQ. FT.
SECOND FLR. -- LIV. AREA	666	
SUBTOTAL, LIVING AREA	1,230	
FLEX	31	
UNIT TOTAL	1,261	
UNIT H2 -- 2-BR 1.5-BA		
FIRST FLOOR -- LIV. AREA	444	SQ. FT.
SECOND FLR. -- LIV. AREA	487	
SUBTOTAL, LIVING AREA	931	
FLEX	46	
UNIT TOTAL	977	
UNIT H3 -- 2-BR 1.5-BA		
FIRST FLOOR -- LIV. AREA	444	SQ. FT.
SECOND FLR. -- LIV. AREA	487	
SUBTOTAL, LIVING AREA	931	
FLEX	46	
UNIT TOTAL	977	
UNIT H4 -- 2-BR 1-BA		
FIRST FLOOR -- LIV. AREA	934	SQ. FT.
FLEX	42	
UNIT TOTAL	976	
BUILDING GRAND TOTAL	4,191	SQ. FT.

STAIR COUNTED AT FIRST FLOOR ONLY, TYP.
PORCHES EXCLUDED, TYP.

EXCAVATION AND FILL

Slope finish grade away from buildings 6 inches minimum for a distance of 10'-0".
Place any large rocks unearthed during excavation near the driveway.

SITE UTILITIES

Connect water service line to water main.
Connect drain lines to sanitary sewer main.
Provide natural gas service entrance and meter.
Provide 200 amp electrical service entrance and meter.
Provide service entrance for Cable TV/Internet.

SITE WORK AND LANDSCAPING

Preserve existing natural vegetation to the extent possible.
Provide house numbers and unit numbers as shown on Elevations.

HEATING

Design of the heating and ventilation systems shall be by Contractor.
Permits shall be acquired and paid for by the Contractor.
Inspections shall be scheduled by the Contractor and/or Subcontractor.
Provide natural gas fired furnace for each living unit, with minimum output of 50 BTUh per square foot of area served.
Locate mechanical equipment in Shared Mechanical Room.

ELECTRICAL

Design of the electrical systems shall be by Contractor.
Permits shall be acquired and paid for by the Contractor.
Inspections shall be scheduled by the Contractor and/or Subcontractor.
Rough in all boxes and conduct a walk-through review of the locations of all power outlets, switches, light fixtures and any other electrical items with Owner prior to wiring.
Provide concealed Cable TV/Internet wiring and wall boxes from service entrance to locations indicated on Floor Plan.
Switched outlets shall be half switched.
Confirm power requirements for all Owner-furnished items.
Provide smoke detectors in each bedroom and on each floor level at high point of ceiling. Provide carbon monoxide detector on each level. Detectors shall be hardwired in a series, so if one sounds they all do, with battery backup.
Provide hardwired doorbell at main entry doors; locate chimes in hallway close to bottom of stairs.

SIDING

Install all siding over air infiltration retarder.
Provide a sample of each type of siding to be used prior to installation or ordering of materials.
Provide siding types as shown on Elevations.
Provide all necessary trim, flashing, terminations and accessories, whether shown/noted or not.

EXTERIOR TRIM

Provide 2x8 cedar fascia, or fiber cement plank same dimension.
Provide window trim, corner trim and other trim as shown/noted.

INSULATION

Provide foundation insulation as shown/noted in Sections and details.
Provide minimum R-20 insulation at foundation walls.
Provide minimum R-21 insulation, batt or blown-in cellulose at exterior walls.
Provide minimum R-38 insulation, foam in place at rim joist.
Provide minimum R-49 insulation, batt or blown-in cellulose at roofs, with minimum 2" vent space above.
Provide minimum R-38 insulation, foam in place at floor cantilevers.
Provide bird screen and insect screen at vent openings.
Vent area shall be equivalent to 1/150th of roof area, 50% at each side at end walls.
Provide 6-mil vapor retarder at warm side of all wall and roof insulation.

ATTIC VENTILATION

See Insulation section.

ROOFING

Provide asphalt composition shingles over ice and water shield (self-adhering modified bitumen membrane).
Provide continuous embedded edge metal flashing at roof edges.
Provide gutter and downspout/s according to best standard local practice. Locate downspout outlets 5'-0" beyond exterior wall.

DRYWALL AND PAINT

Provide 1/2" gypsum board at walls.
Provide 5/8" gypsum board at ceilings.
Provide samples of wall texture and paint/stain color samples, prior to commencement of work or ordering of materials.
Provide exterior grade primer and paint at any siding types not supplied prefinished; and exterior soffit and fascia.
Provide exterior-grade stain at exposed truss tails and underside of sheathing.
Provide primer and two coats of water based latex enamel at interior.

INTERIOR TRIM

Typical base trim and door trim shall be rectangular MDF or 4" rubber base as selected.
Prime and paint MDF with two coats semi-gloss, color to match adjacent walls.
Window trim shall be min. 3/4" rectangular clear hem-fir, poplar or MDF sill with gypsum board returns at jambs and head. Gypsum board returns four sides OK for high windows.

CRAWL SPACE VENTILATION

Crawl spaces shall be mechanically ventilated.
Provide constant velocity fan with 1 CFM per square foot of crawl space footprint.
Transfer grilles, floor openings located opposite of fan/discharge to pull air across crawl space.
Design and installation by Contractor.
Comply with IRC 408.3, 2.1.

BUILDING CODE SUMMARY

International Residential Code, 2018 edition

Use - fourplex with townhouse units. R202

Allowable number of stories - 3

Actual number of stories - 2

Exterior walls are not required to be fire rated, min. 5'-0" fire separation at property line. Table R302.1 (1)

Smoke alarms are required. R314

Address identifying signage is required. R319

Minimum stairway width, 36". R311.7.1

Stairway maximum riser height, 7-3/4"; minimum tread depth, 10".

R311.7.5.1, R311.7.5.2

Handrails - one side of stair runs only. Handrails are not required at stair flights with three or fewer risers. R311.7.8

Handrail height - 34" above nosings, except at transitions as allowed by R311.7.8.1, exception 2.

Guard height - minimum 34" above stair nosings. R312.1.2, exception 1

Guard height - minimum 36" at deck railing and any other locations not along stair runs. R312.1.1

Accessible unit shall comply with Uniform Federal Accessibility Standards (UFAS), 1984.

ZONING CODE SUMMARY

Title 21, Anchorage Municipal Code

Zoning district: R-3

Property area: 47,418 sq. ft.

Lot coverage, allowed: 40% [multifamily]; 60% [townhouse] Table 21.06-1

Lot coverage, proposed: 49.3%

Height, allowed: 35 ft. Table 21.06-1

Height, proposed: 23 ft.

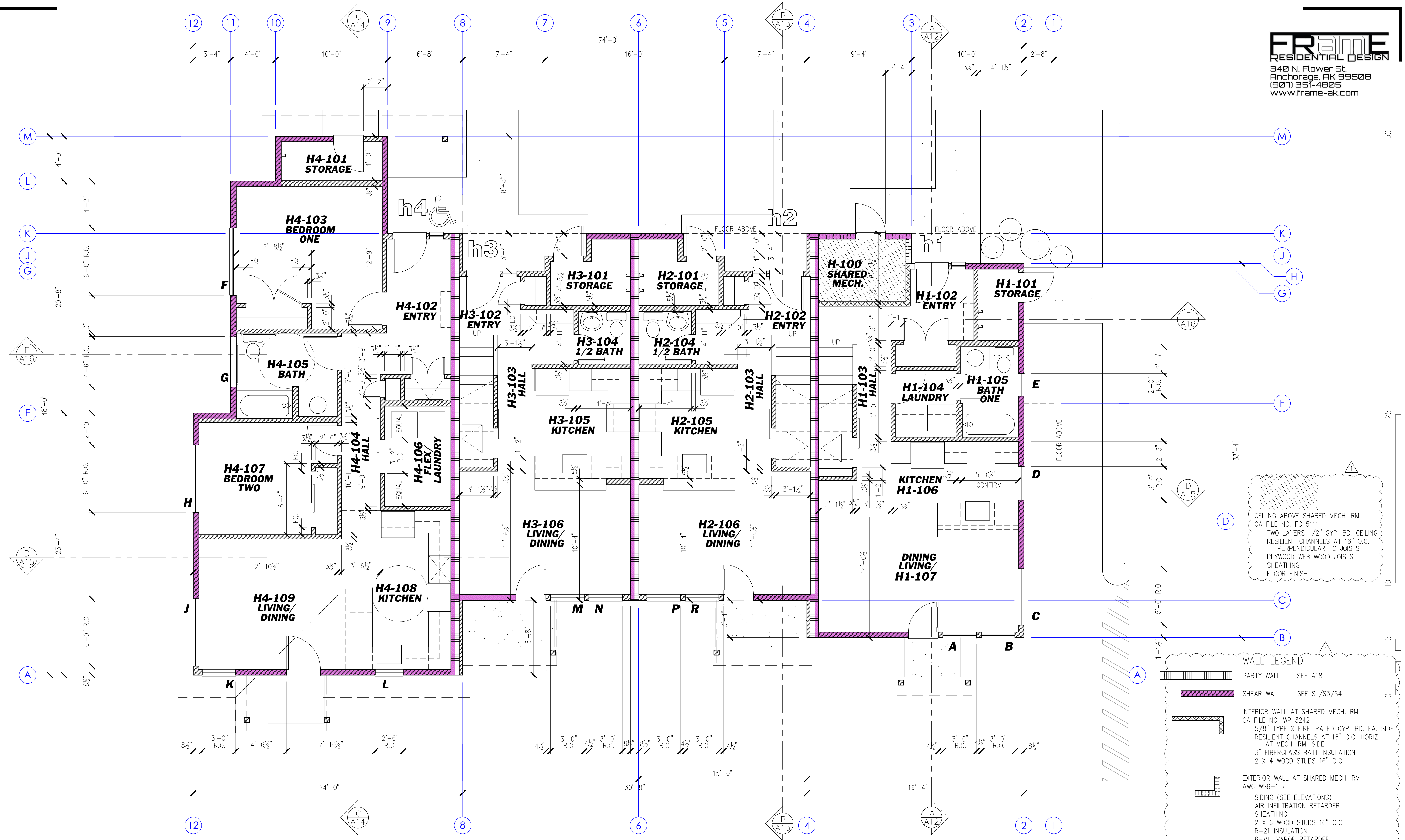

CEILING ABOVE SHARED MECH. RM.
GA FILE NO. FC 5111
TWO LAYERS 1/2" GYP. BD. CEILING
RESILIENT CHANNELS AT 16" O.C.
PERPENDICULAR TO JOISTS
PLYWOOD WEB WOOD JOISTS
SHEATHING
FLOOR FINISH

WALL LEGEND

- PARTY WALL --- SEE A18
- SHEAR WALL --- SEE S1/S3/S4
- INTERIOR WALL AT SHARED MECH. RM.
GA FILE NO. WP 3242
5/8" TYPE X FIRE-RATED GYP. BD. EA. SIDE
RESILIENT CHANNELS AT 16" O.C. HORIZ.
AT MECH. RM. SIDE
3" FIBERGLASS BATT INSULATION
2 X 4 WOOD STUDS 16" O.C.
- EXTERIOR WALL AT SHARED MECH. RM.
AWC WS6-1.5
SIDING (SEE ELEVATIONS)
AIR INFILTRATION RETARDER
SHEATHING
2 X 6 WOOD STUDS 16" O.C.
R-21 INSULATION
6-MIL VAPOR RETARDER
5/8" TYPE X FIRE-RATED GYP. BD.

BUILDING H
Overall
First Floor Plan

COOK INLET HOUSING AUTHORITY
BAXTER MULTIPLEXES, PHASE II
Tract B, valetskaya Addition No. 1
NHN Erna Court
ANCHORAGE, ALASKA

3/31/26
DR. BY: CLARK
DATE: 23 JAN 26

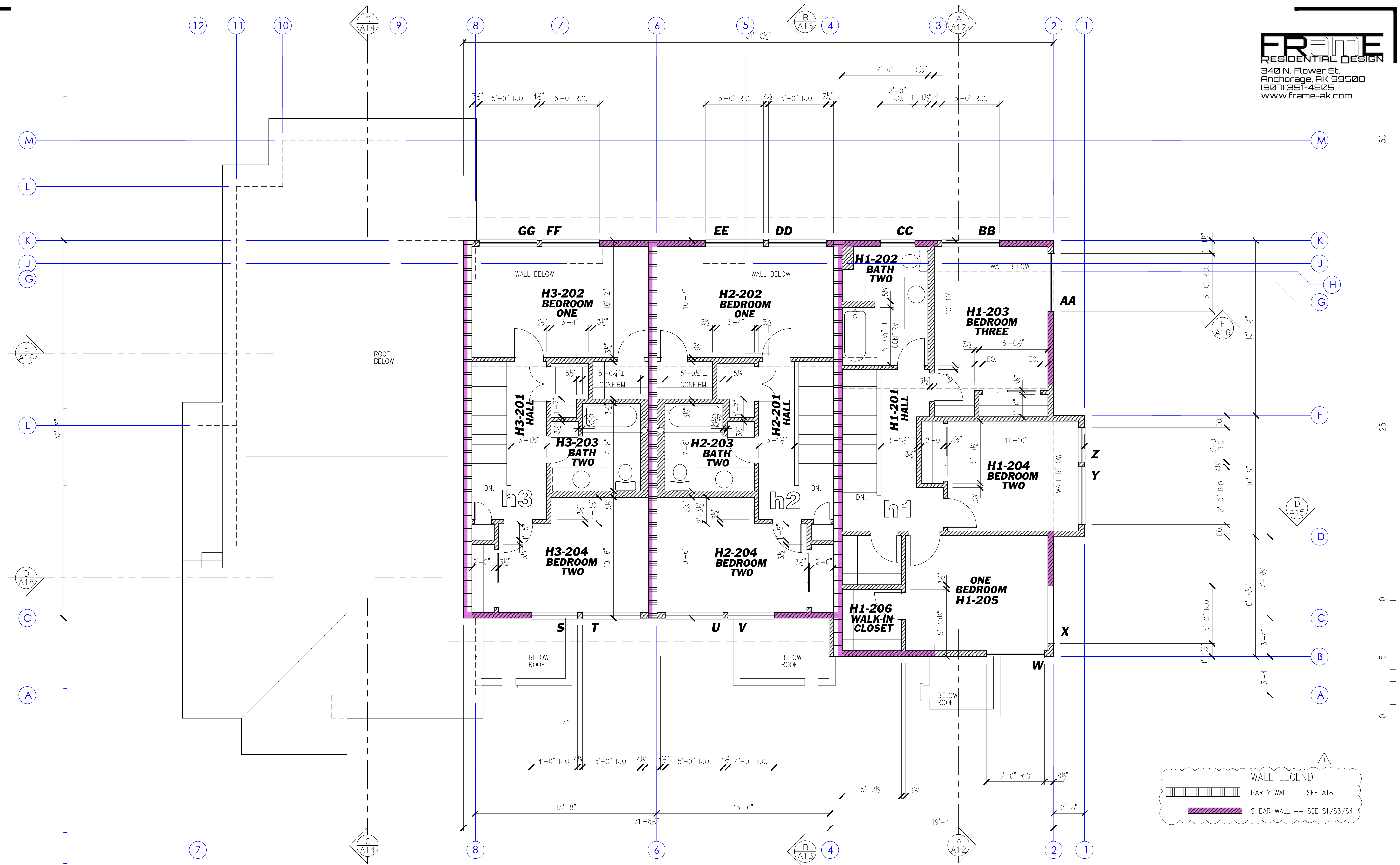

BUILDING H
Overall
Second Floor Plan

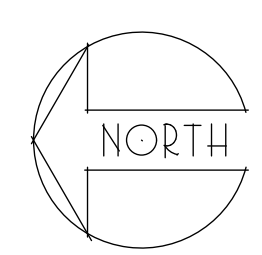

COOK INLET HOUSING AUTHORITY
BAXTER MULTIPLEXES, PHASE II
Tract B, valetkaya Addition No. 1
NHN Erna Court
ANCHORAGE, ALASKA

3/31/26
DR. BY: CLARK
DATE: 23 JAN 26

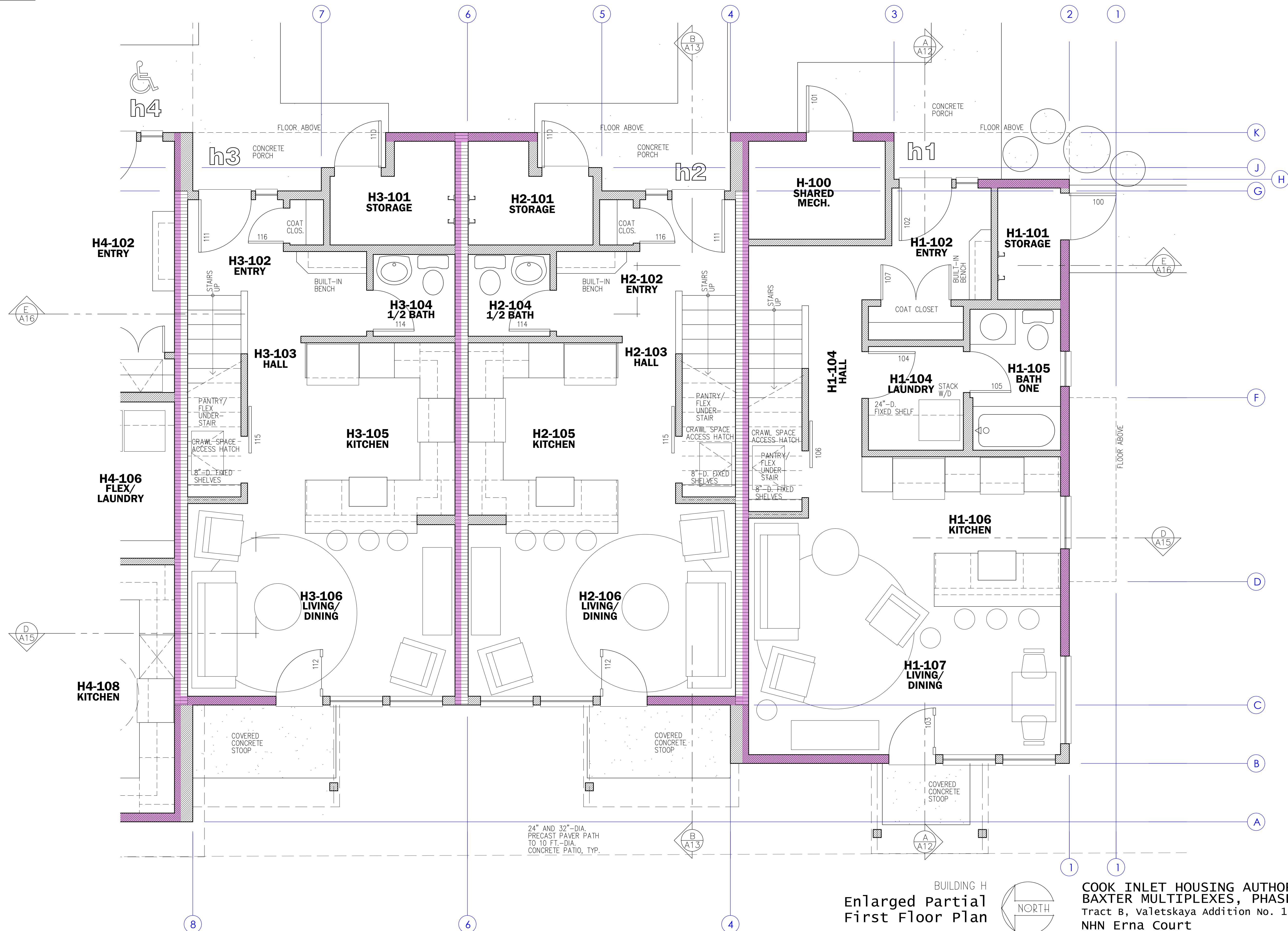

BUILDING H
Enlarged Partial
First Floor Plan



COOK INLET HOUSING AUTHORITY
BAXTER MULTIPLEXES, PHASE II
Tract B, valetskaya Addition No. 1
NHN Erna Court
ANCHORAGE, ALASKA

DR. BY: CLARK
DATE: 23 JAN 26

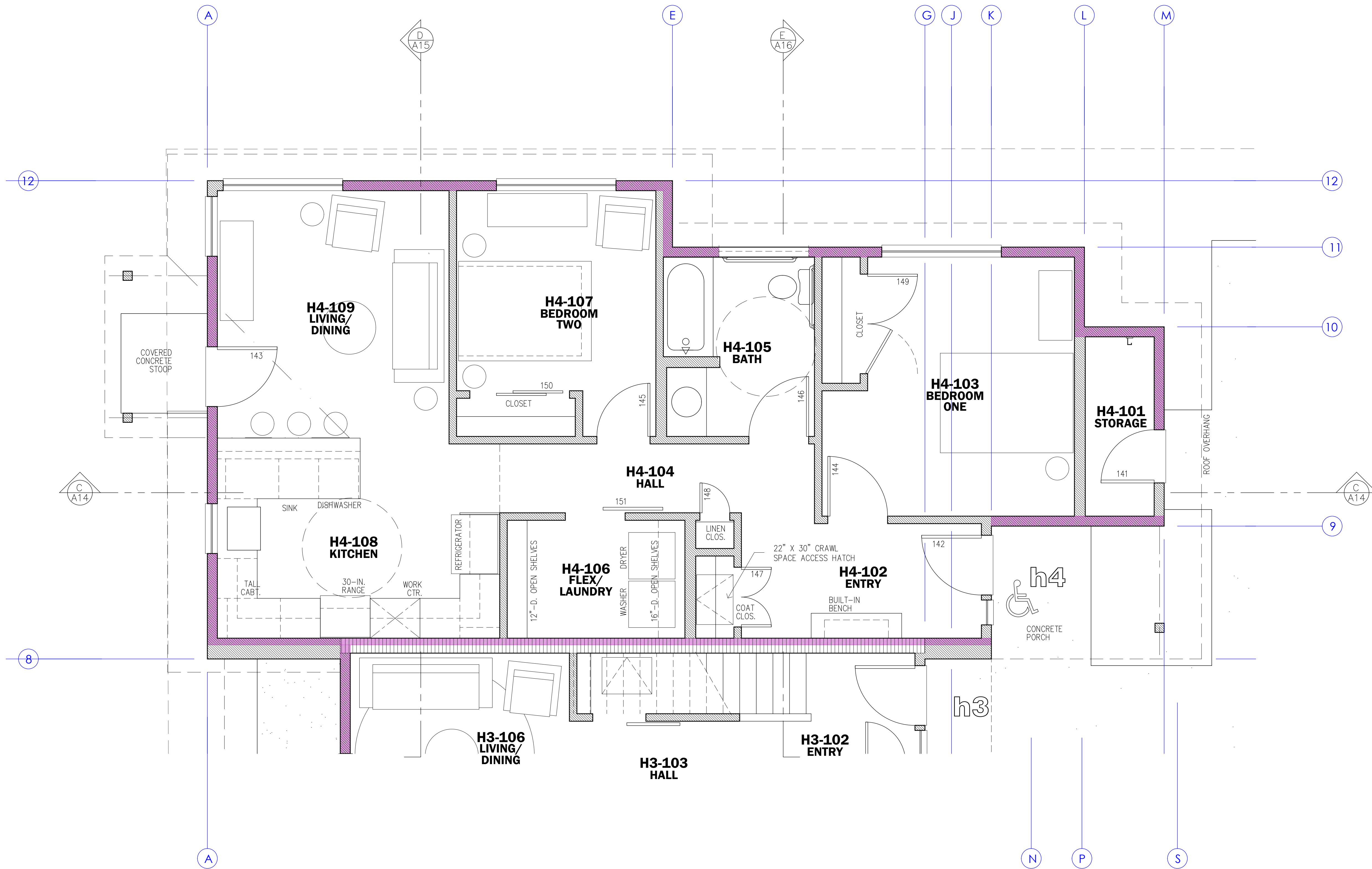

25
10
5
0

BUILDING H
 Enlarged Partial
 First Floor Plan

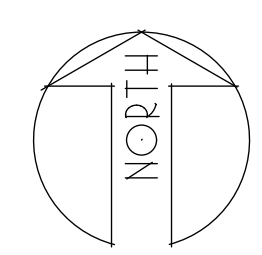

COOK INLET HOUSING AUTHORITY
 BAXTER MULTIPLEXES, PHASE II
 Tract B, valetskaya Addition No. 1
 NHN Erna Court
 ANCHORAGE, ALASKA

DR. BY: CLARK
 DATE: 23 JAN 26

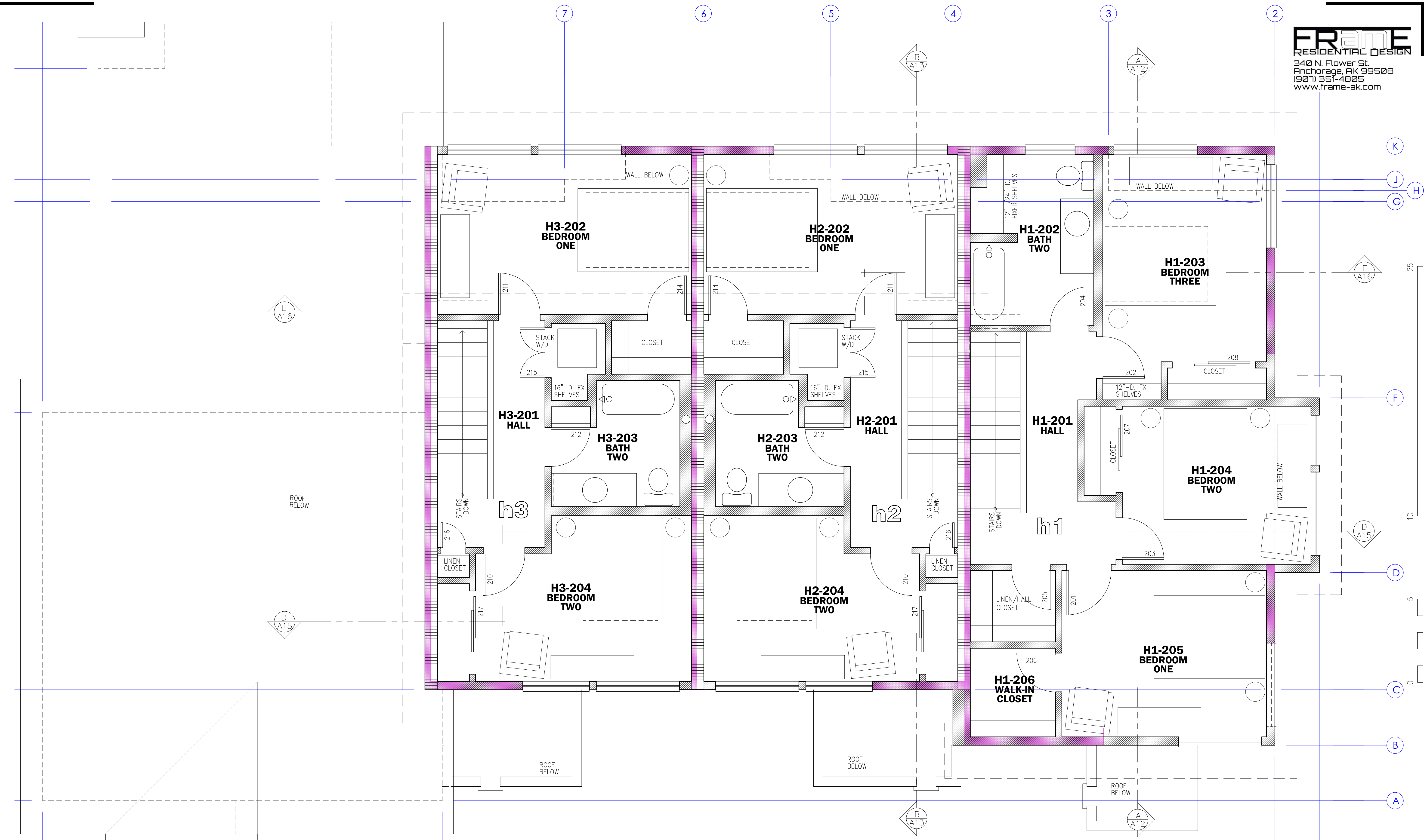

BUILDING H
 Enlarged
 Second Floor Plan

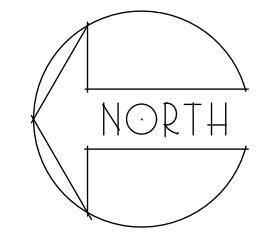

COOK INLET HOUSING AUTHORITY
 BAXTER MULTIPLEXES, PHASE II
 Tract B, valetskaya Addition No. 1
 NHN Erna Court
 ANCHORAGE, ALASKA

DR. BY: CLARK
 DATE: 23 JAN 26

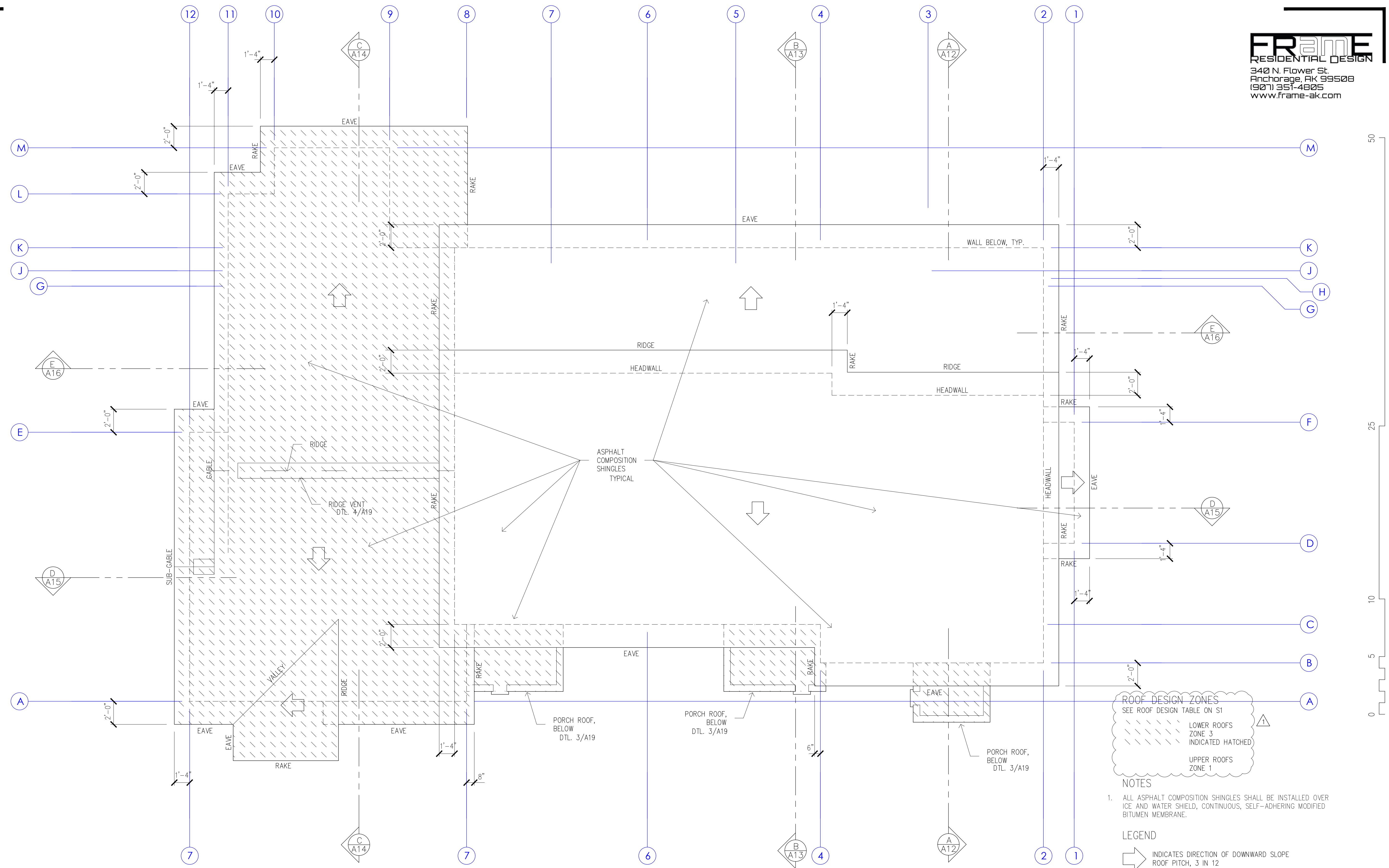

ASPHALT
COMPOSITION
SHINGLES
TYPICAL

ROOF DESIGN ZONES
SEE ROOF DESIGN TABLE ON S1

- LOWER ROOFS
ZONE 3
INDICATED HATCHED
- UPPER ROOFS
ZONE 1

NOTES

- ALL ASPHALT COMPOSITION SHINGLES SHALL BE INSTALLED OVER ICE AND WATER SHIELD, CONTINUOUS, SELF-ADHERING MODIFIED BITUMEN MEMBRANE.

LEGEND

INDICATES DIRECTION OF DOWNWARD SLOPE
ROOF PITCH, 3 IN 12

BUILDING H
Roof Plan

**COOK INLET HOUSING AUTHORITY
BAXTER MULTIPLEXES, PHASE II
Tract B, valetskaya Addition No. 1
NHN Erna Court
ANCHORAGE, ALASKA**

3/31/26
DR. BY: CLARK
DATE: 23 JAN 26

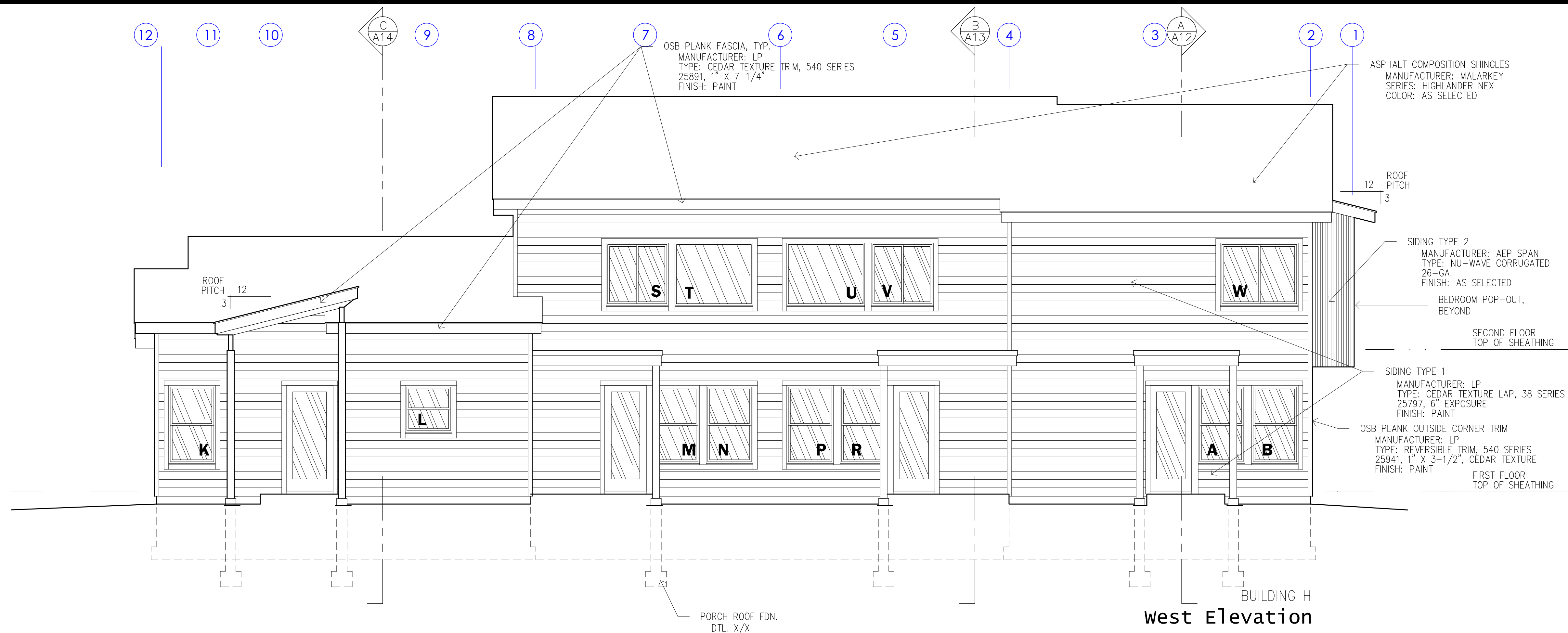

BUILDING H
West Elevation

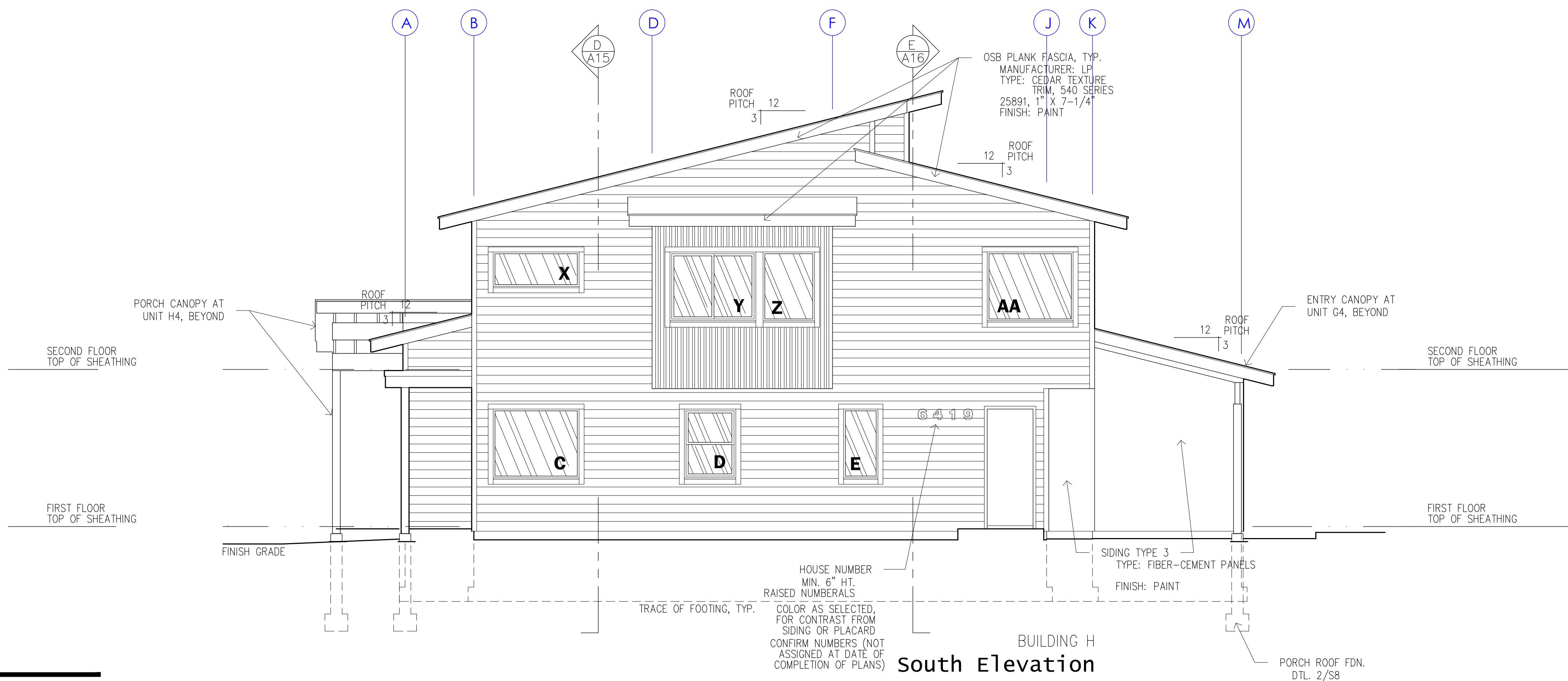

BUILDING H
South Elevation

COOK INLET HOUSING AUTHORITY
BAXTER MULTIPLEXES, PHASE II
Tract B, valetskaya Addition No. 1
NHN Erna Court
ANCHORAGE, ALASKA

3/31/26
DR. BY: CLARK
DATE: 23 JAN 26

A10
10 OF 28

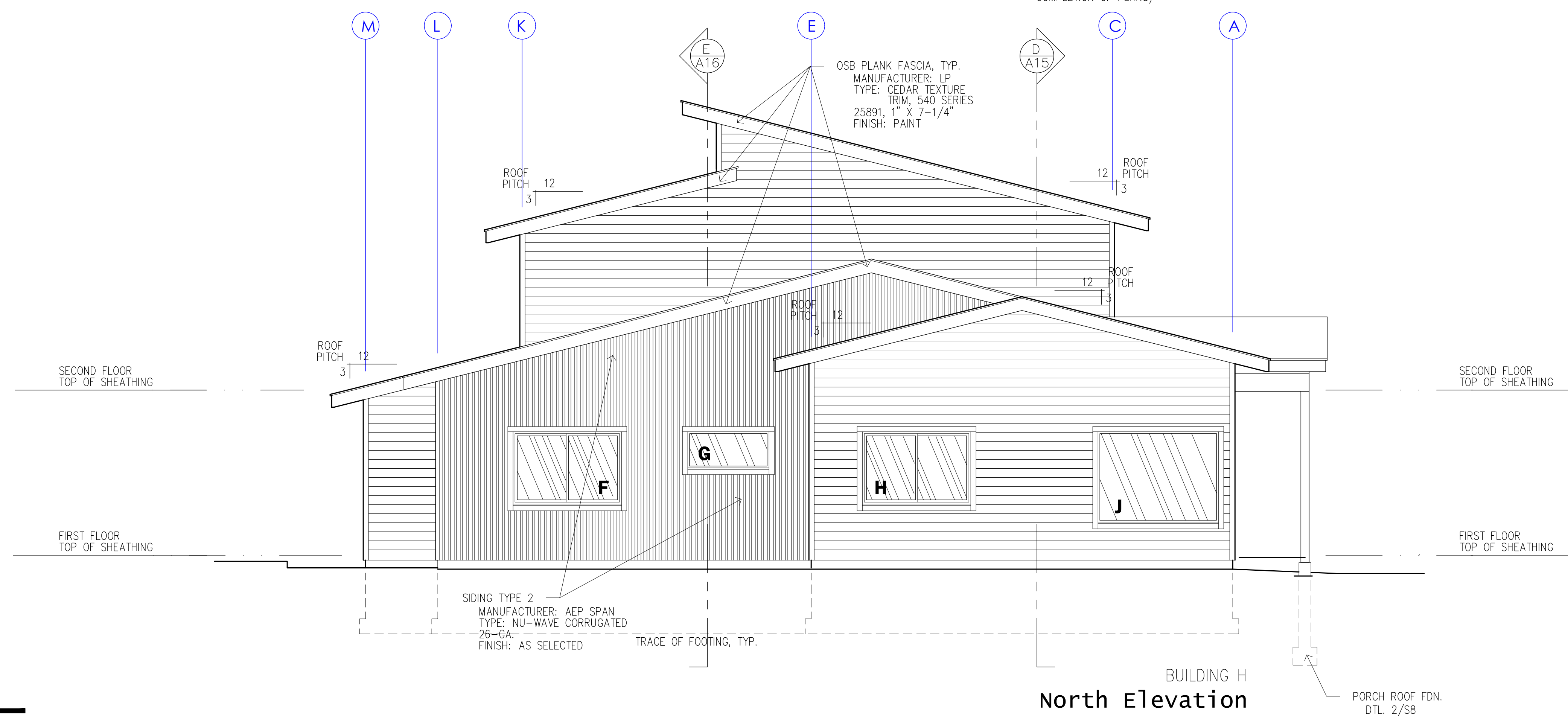
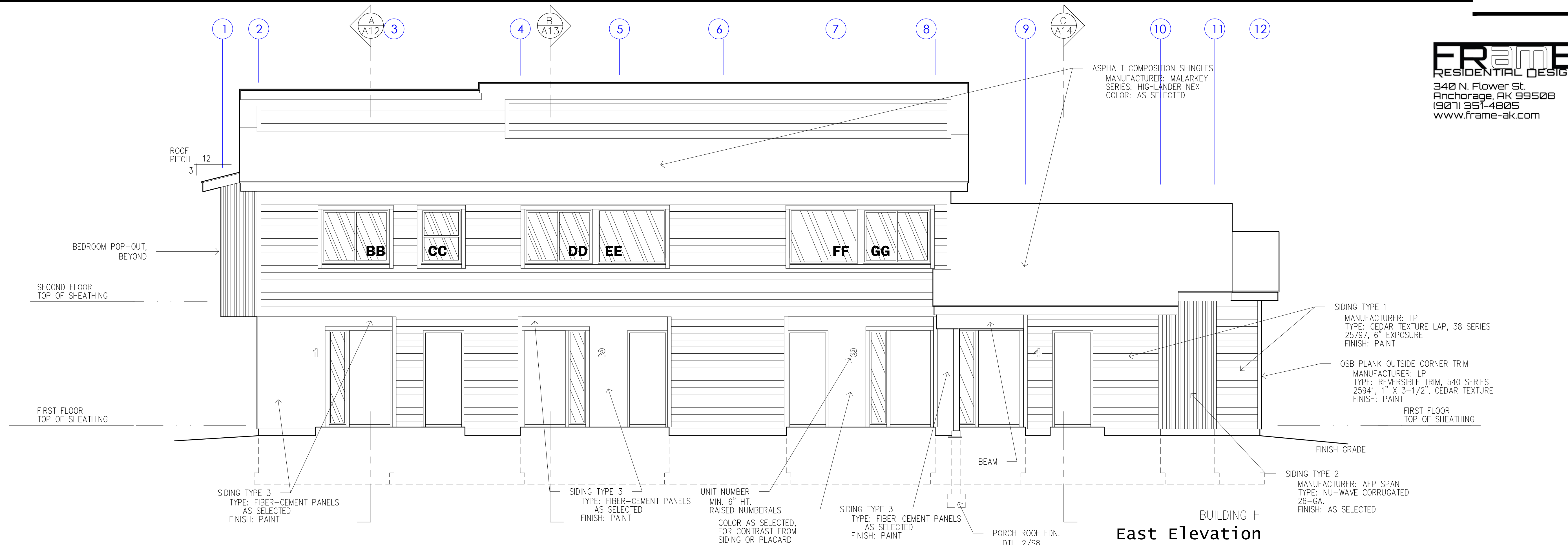

COOK INLET HOUSING AUTHORITY
BAXTER MULTIPLEXES, PHASE II
Tract B, valetskaya Addition No. 1
NHN Erna Court
ANCHORAGE, ALASKA

3/31/26
DR. BY: CLARK
DATE: 23 JAN 26

A11
11 of 28

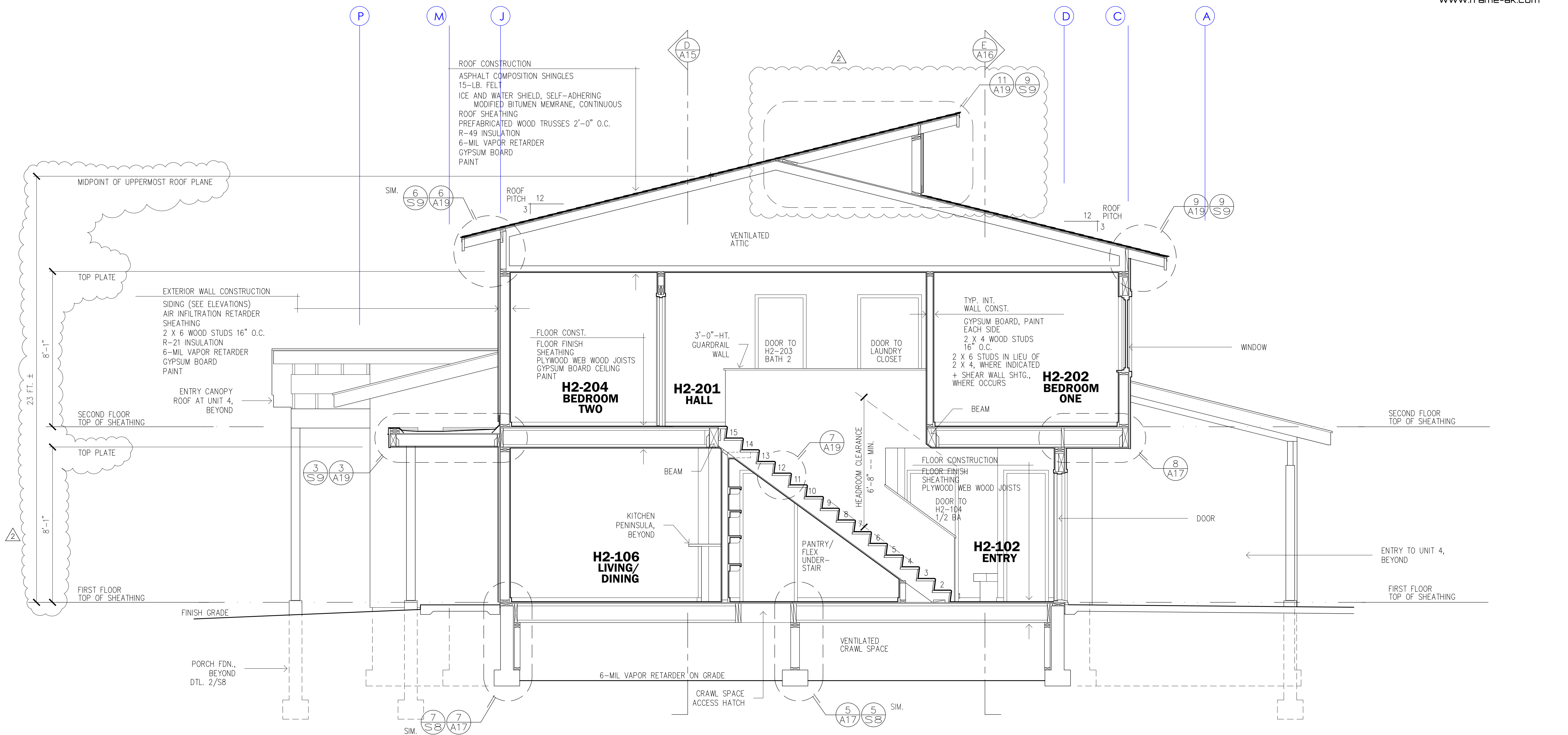

BUILDING H
Building Section B--B

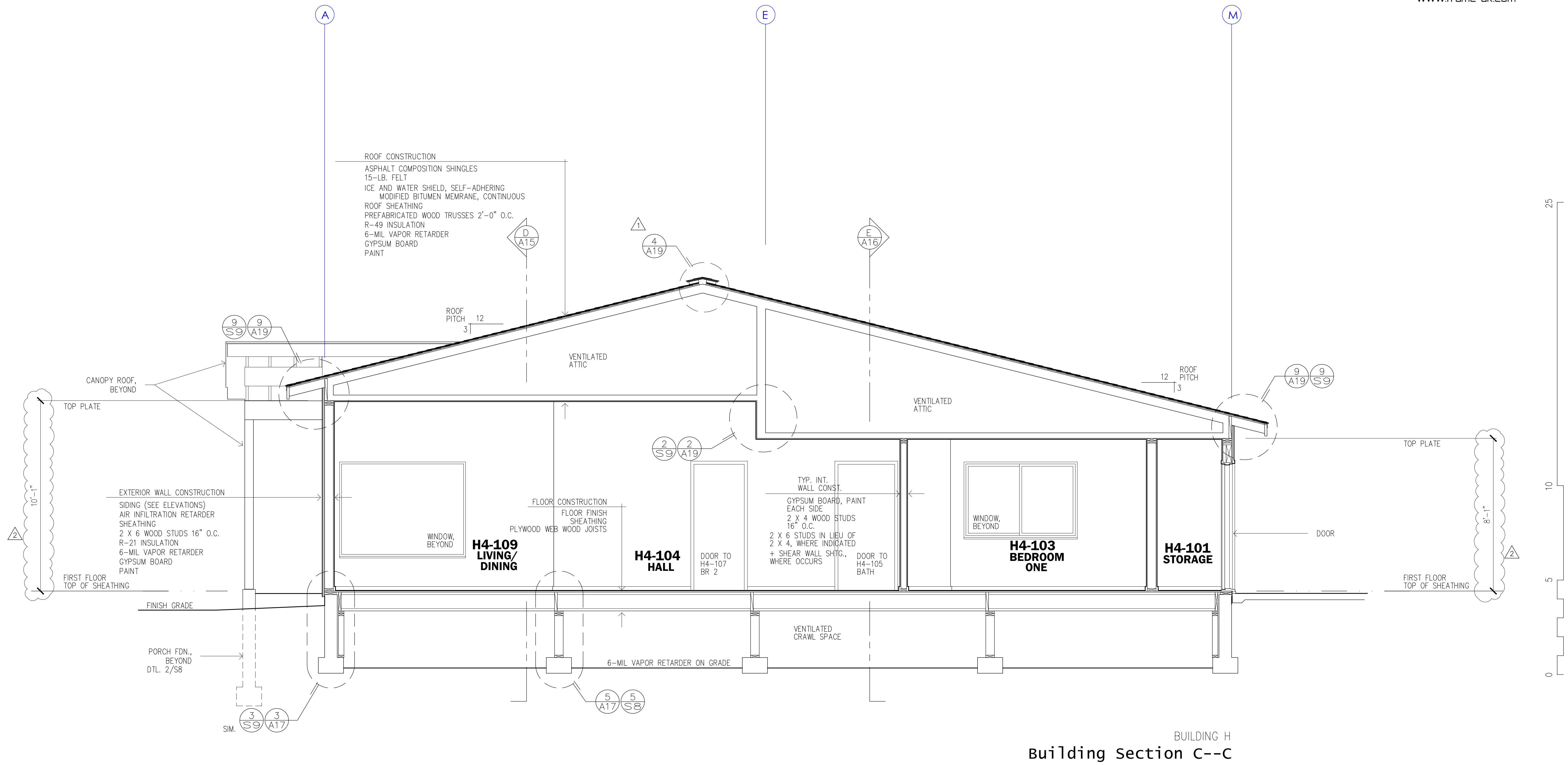

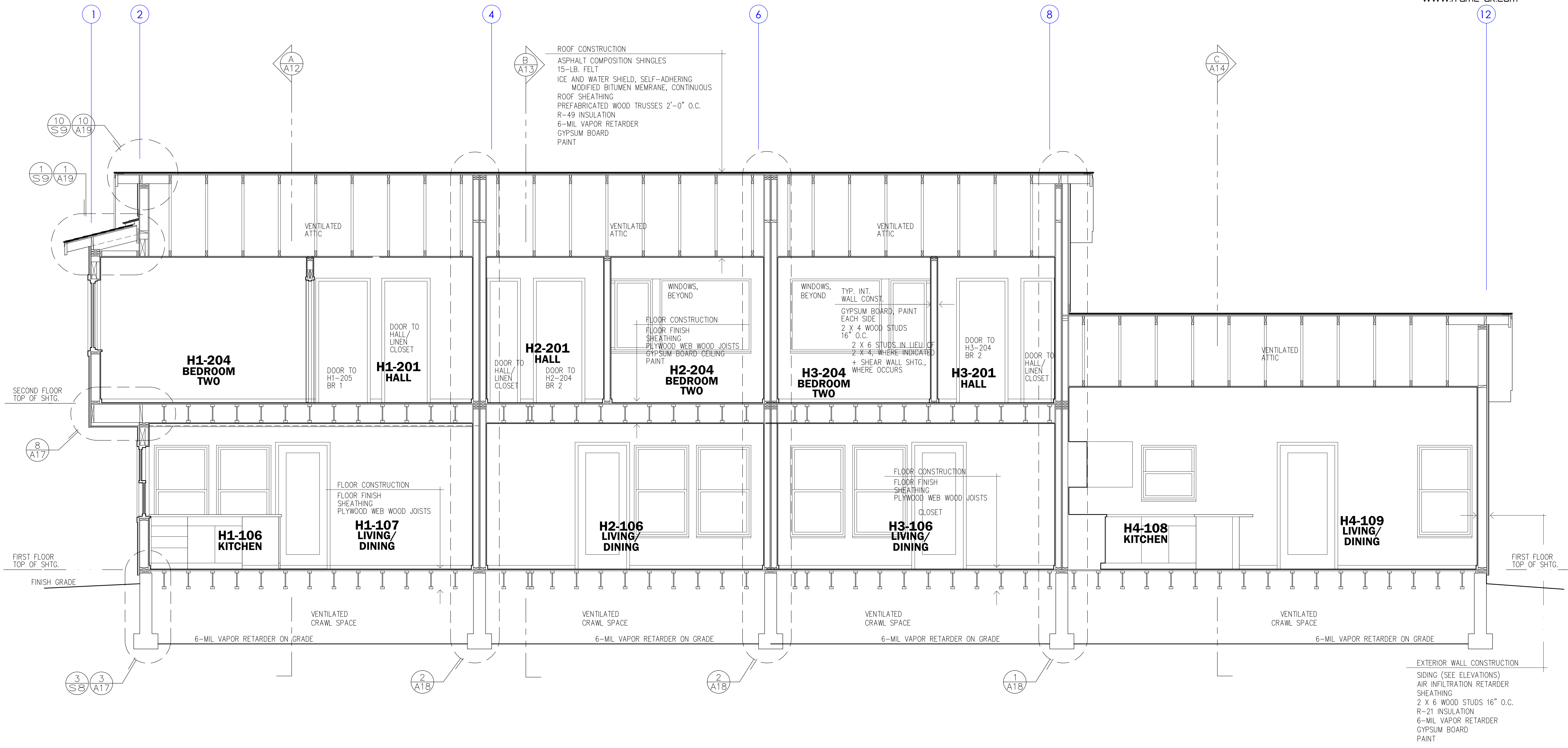

BUILDING H
Building Section D--D

COOK INLET HOUSING AUTHORITY
BAXTER MULTIPLEXES, PHASE II
Tract B, valetkaya Addition No. 1
NHN Erna Court
ANCHORAGE, ALASKA



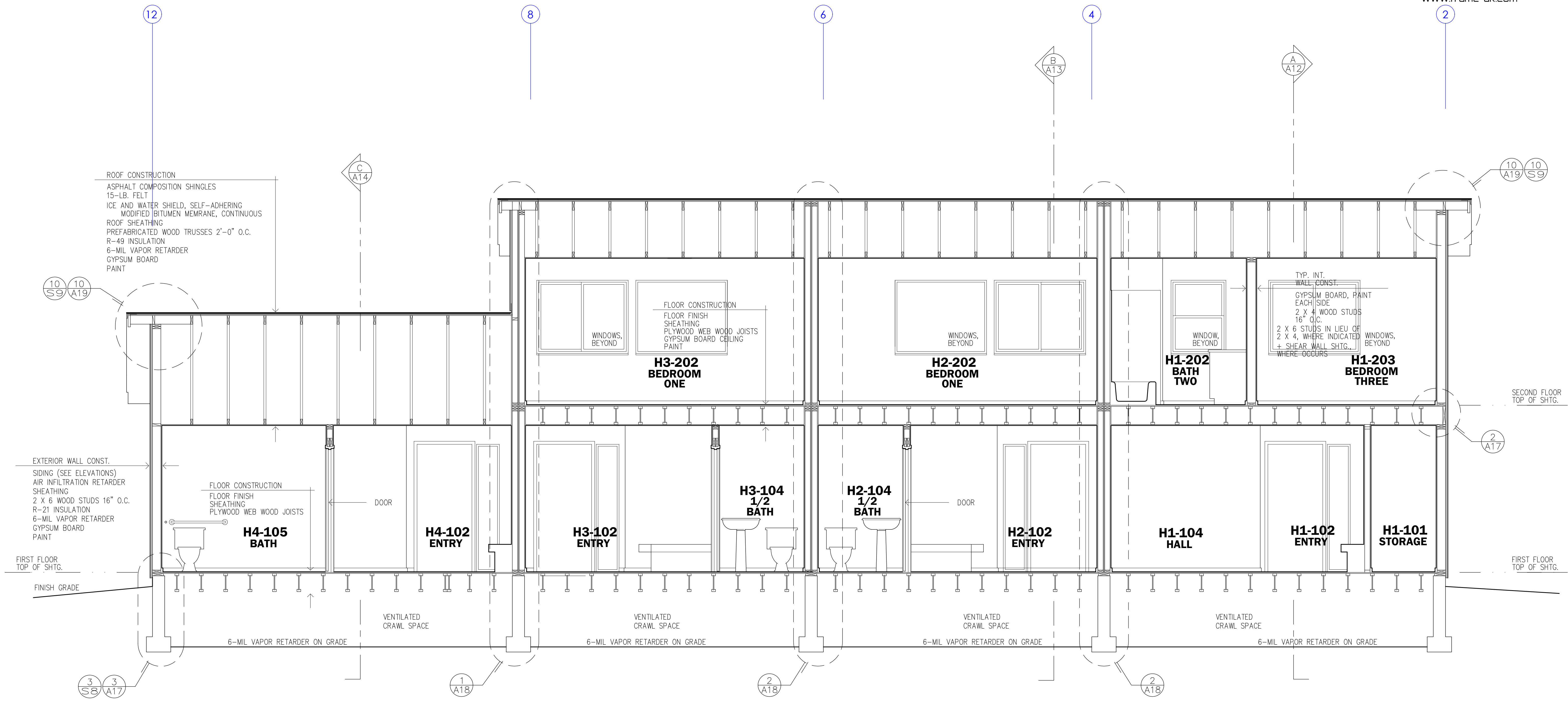

BUILDING H
Building Section E--E

COOK INLET HOUSING AUTHORITY
BAXTER MULTIPLEXES, PHASE II
Tract B, valetskaya Addition No. 1
NHN Erna Court
ANCHORAGE, ALASKA



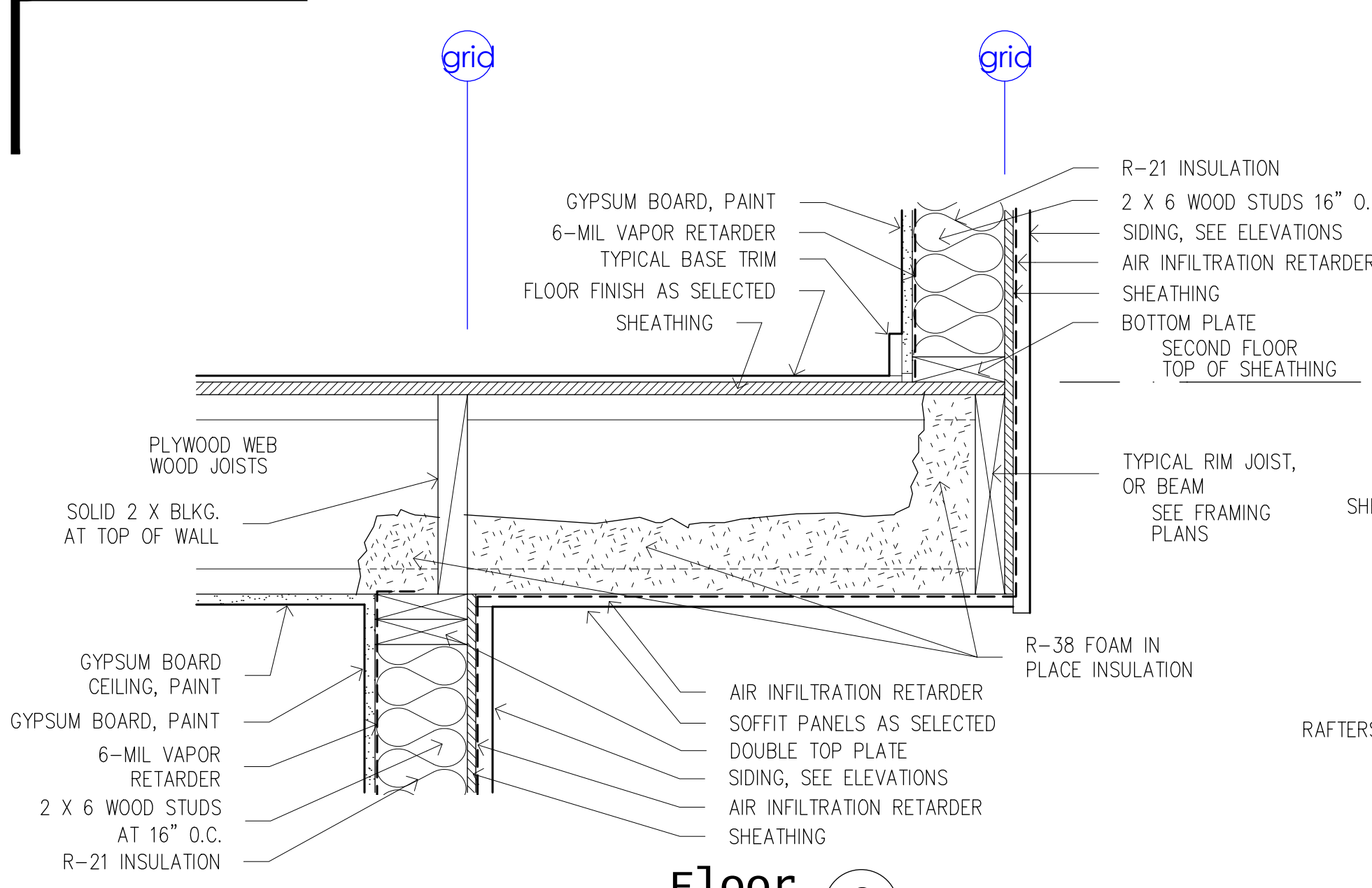

Floor cantilever 8

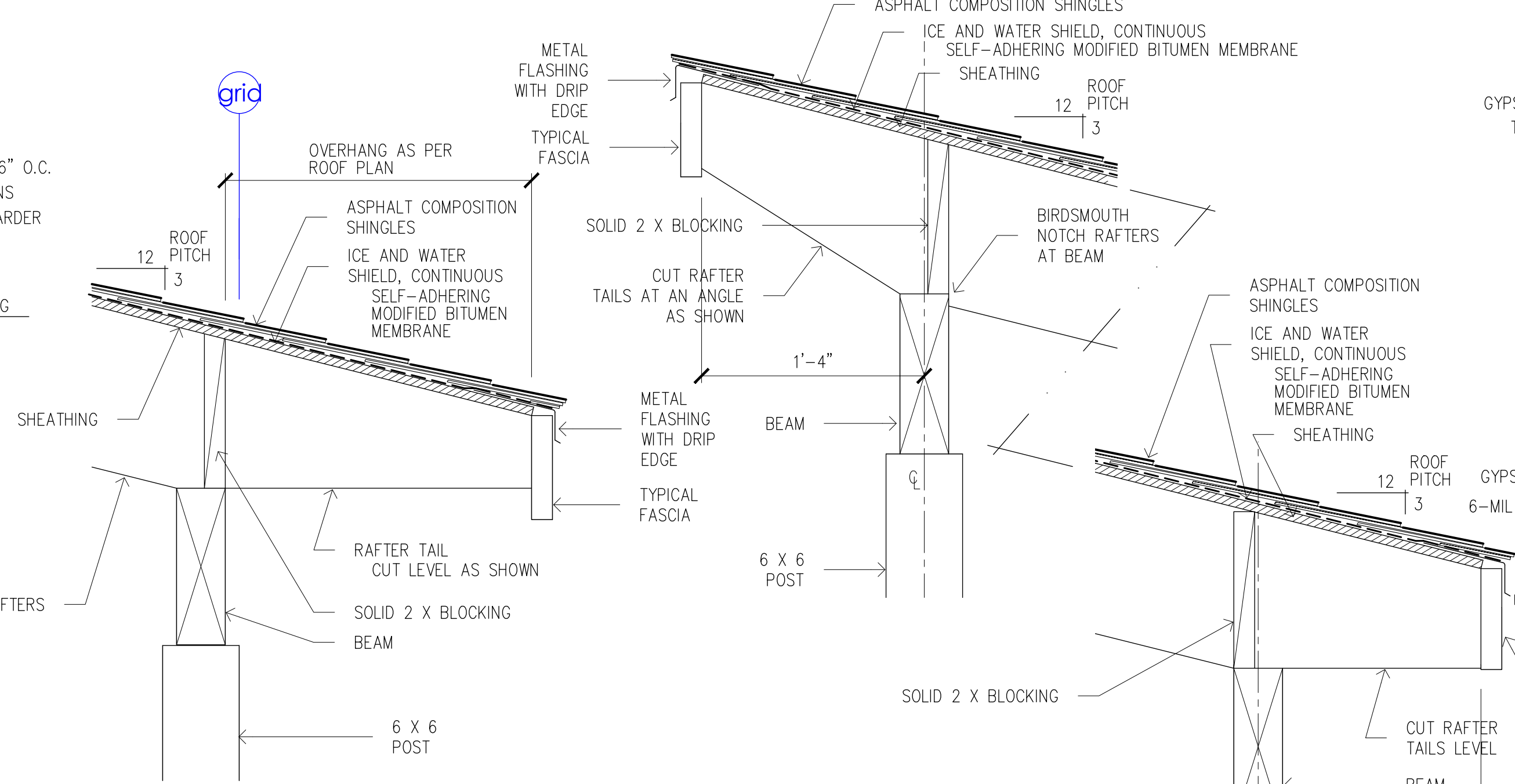

Eave at Unit #4 Entry Canopy 6

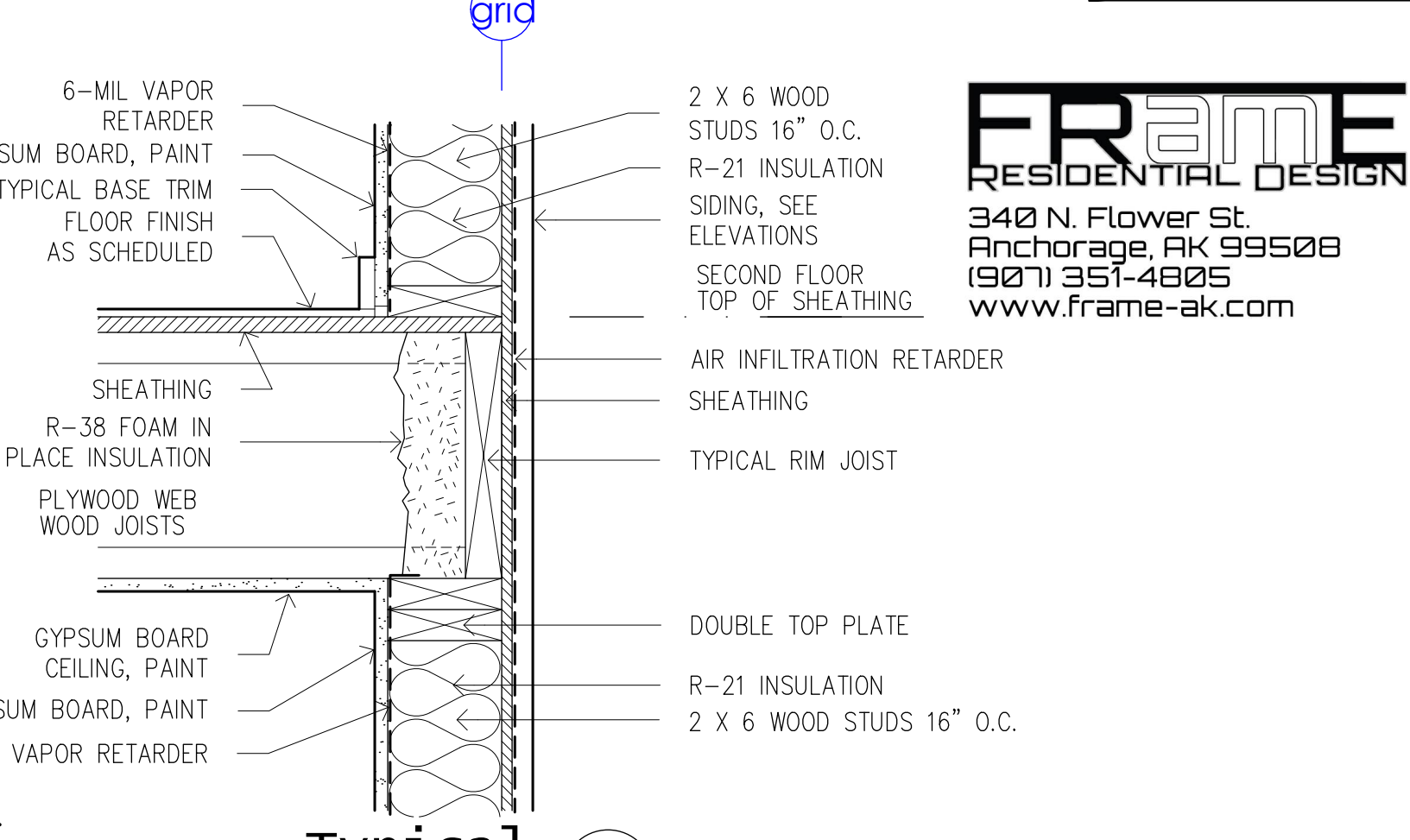

Typical Rim Joist 2

Back Porch Canopy at Unit #4 4
SEE DTL. 4/S9 FOR ADDITIONAL INFORMATION

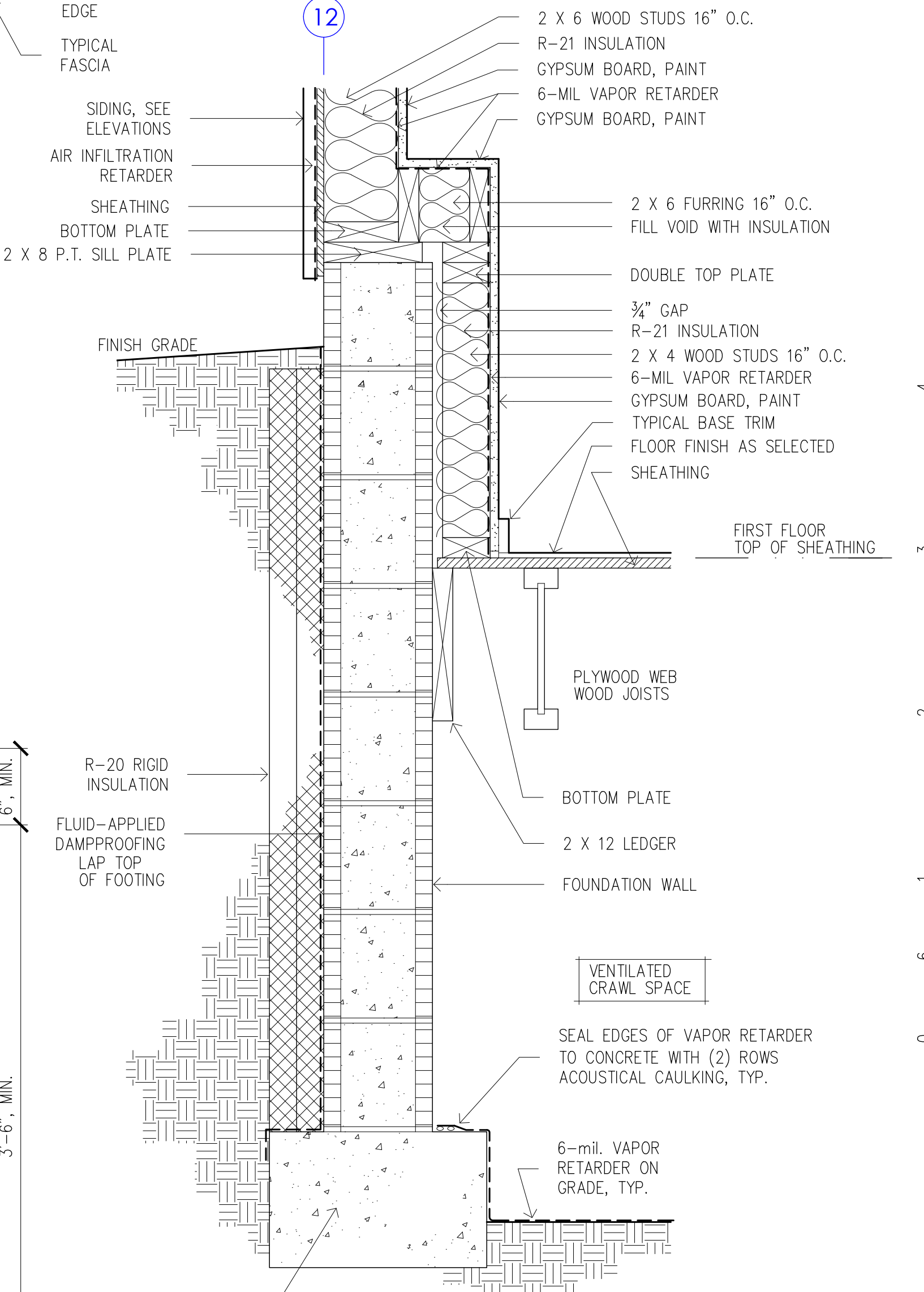

North wall Foundation 1
SEE DTL. 1/S8 FOR ADDITIONAL INFORMATION

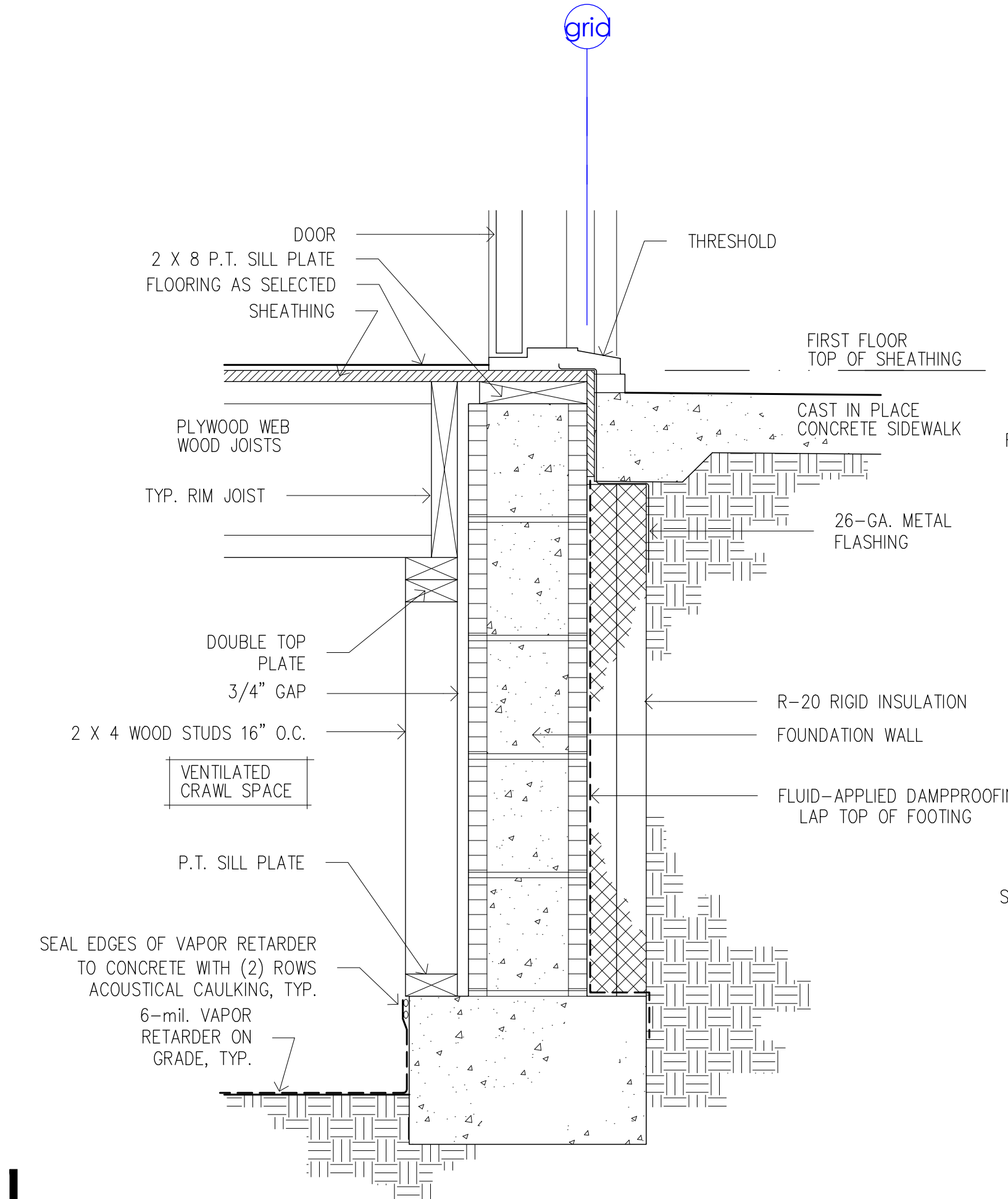

Typical Foundation wall 7
SEE DTL. 7/S8 FOR ADDITIONAL INFORMATION

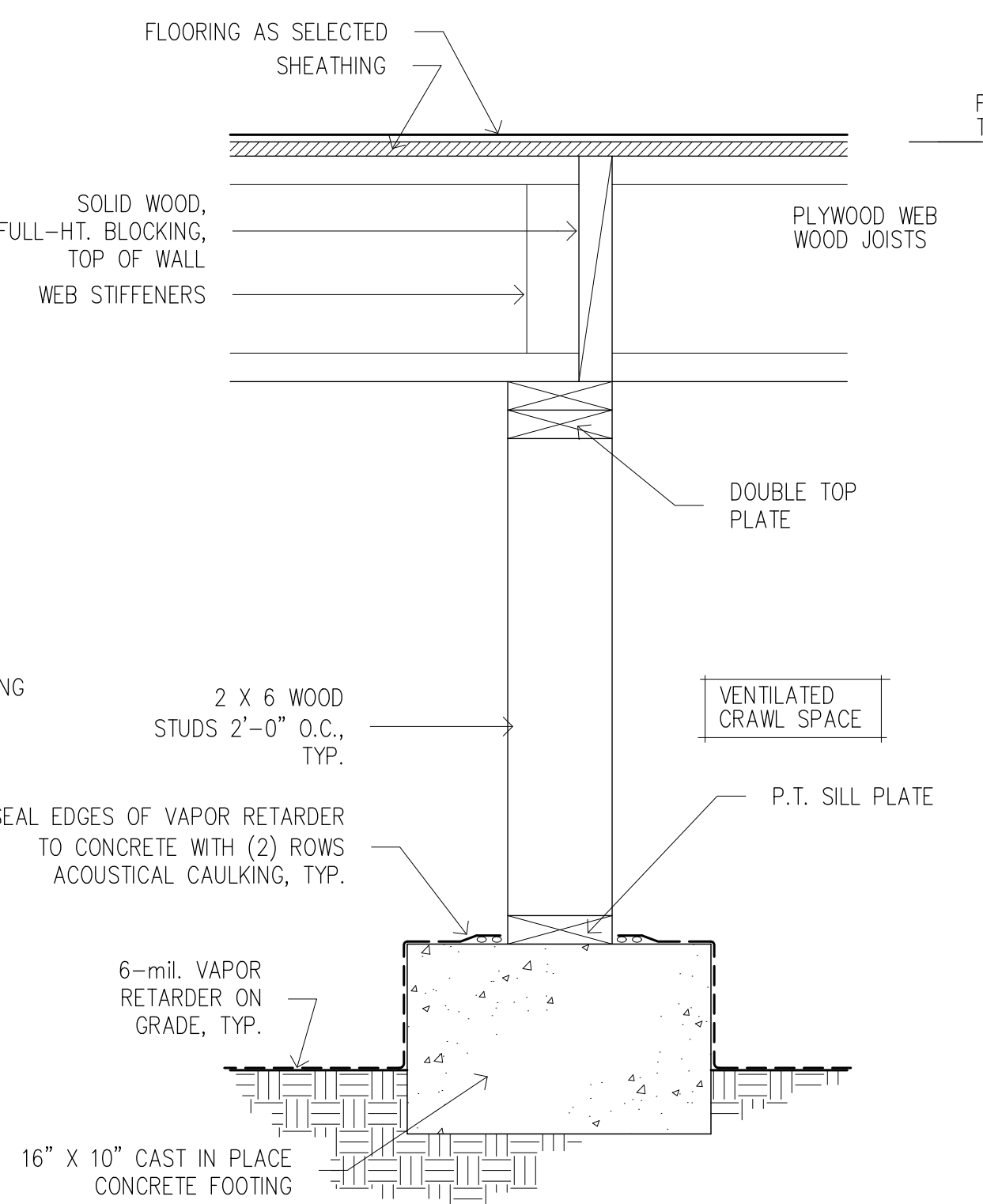

Typical Pony wall 5
SEE DTL. 5/S8 FOR ADDITIONAL INFORMATION

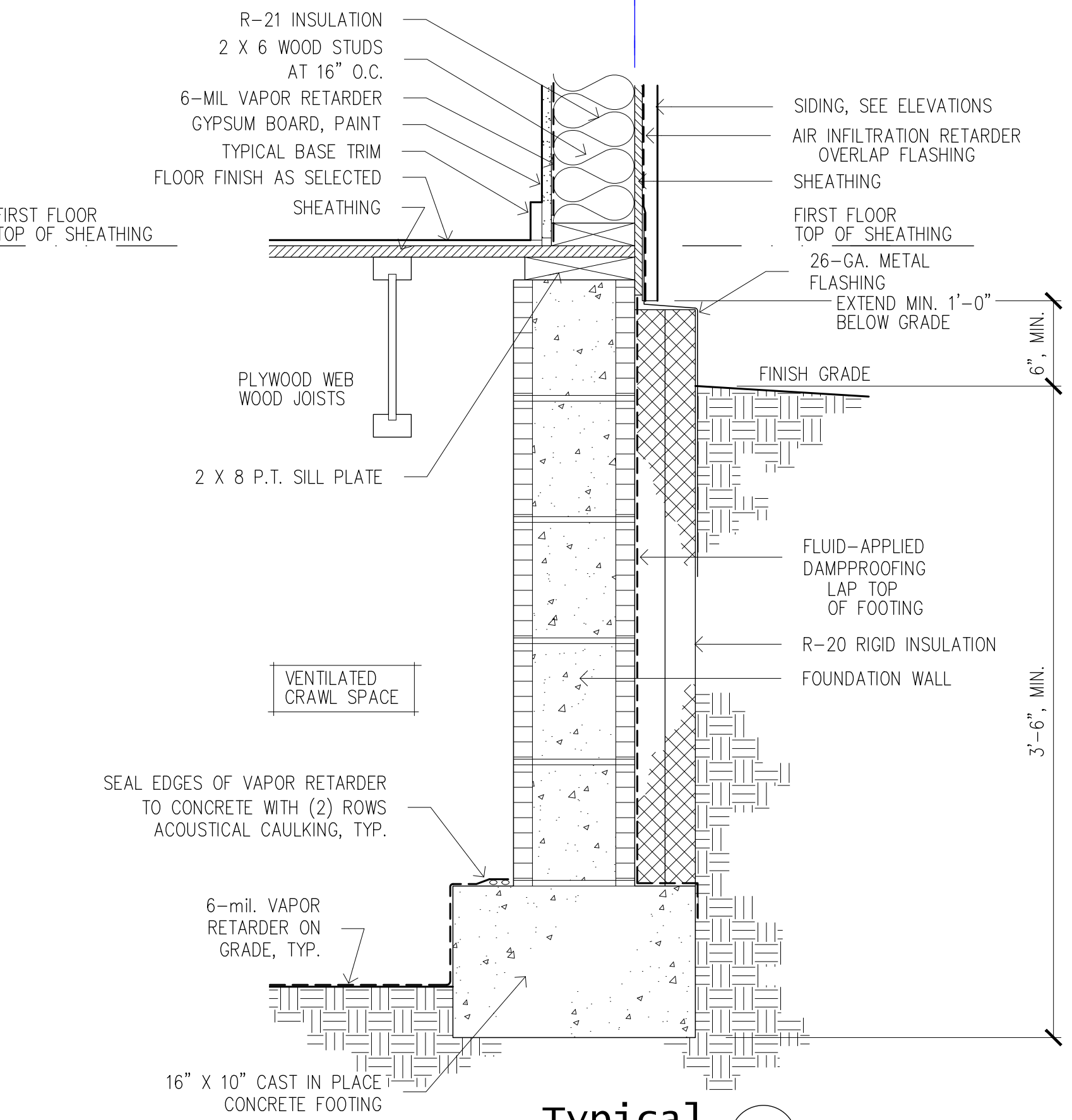

Typical Foundation wall 3
SEE DTL. 3/S8 FOR ADDITIONAL INFORMATION

**COOK INLET HOUSING AUTHORITY
BAXTER MULTIPLEXES, PHASE II
Tract B, valetskaya Addition No. 1
NHN Erna Court
ANCHORAGE, ALASKA**

DR. BY: CLARK
DATE: 23 JAN 26

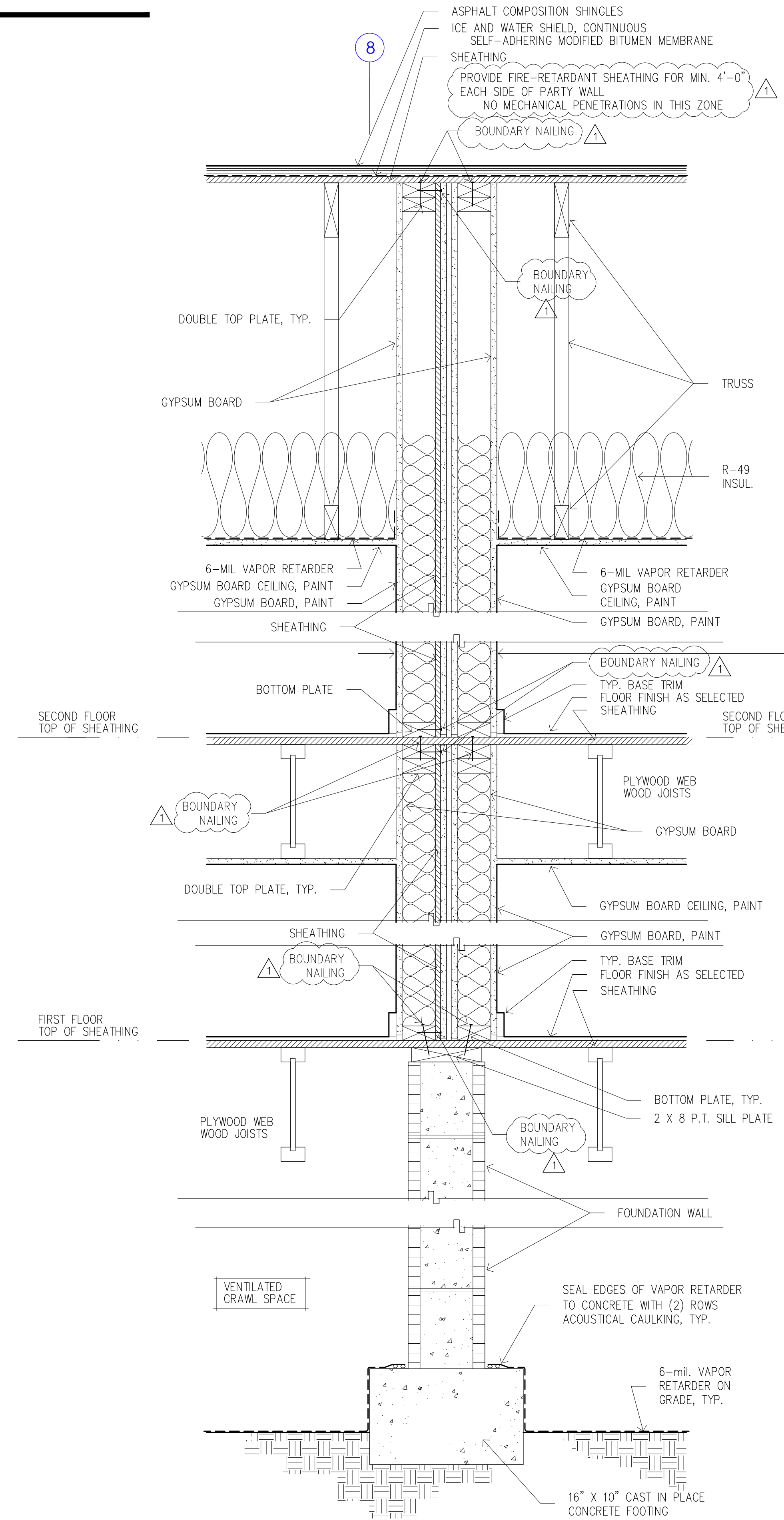

Party wall 2

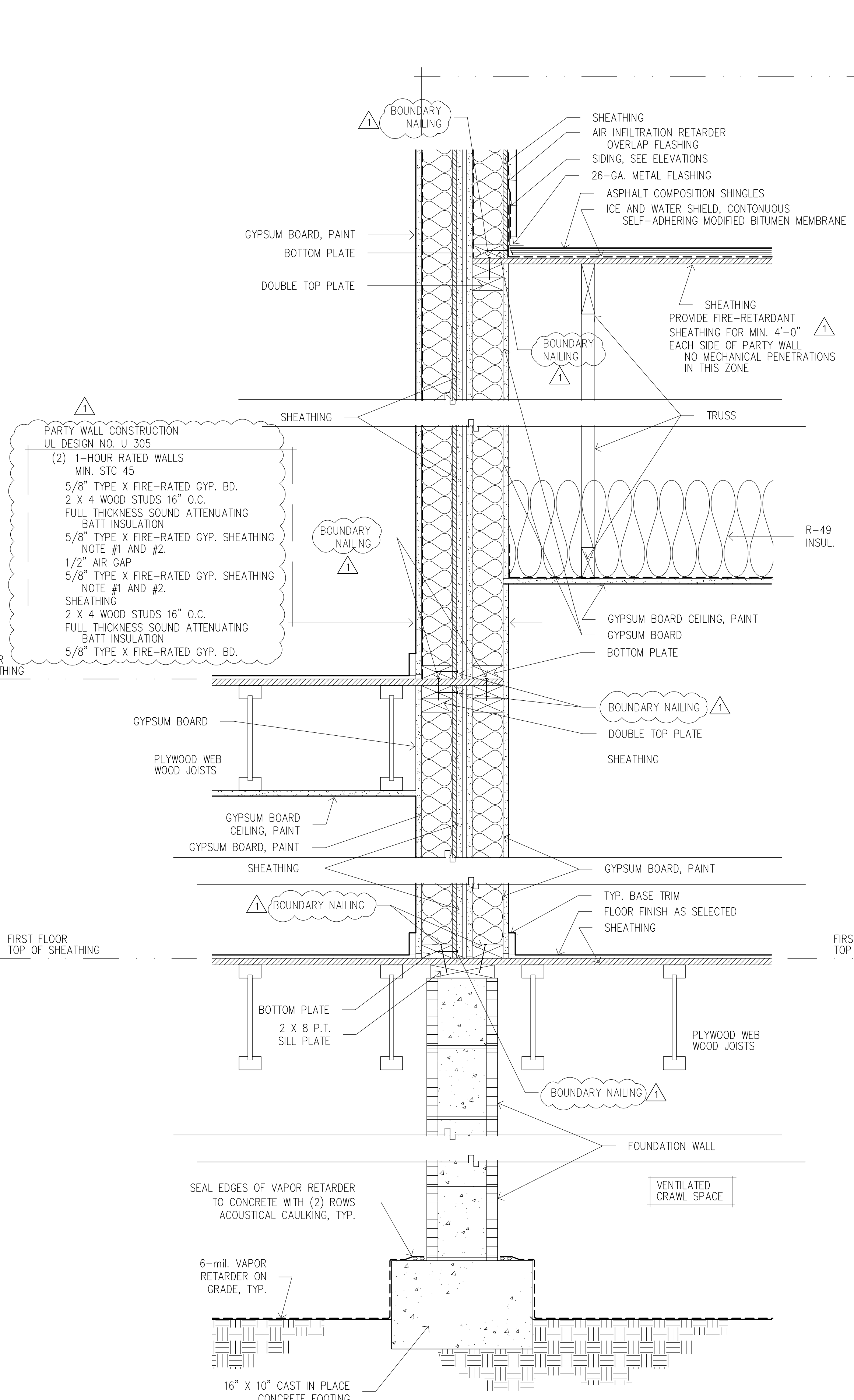

Party wall 1

1
PARTY WALL CONSTRUCTION
UL DESIGN NO. U 305
(2) 1-HOUR RATED WALLS
MIN. STC 45
5/8" TYPE X FIRE-RATED GYP. BD.
2 X 4 WOOD STUDS 16" O.C.
FULL THICKNESS SOUND ATTENUATING
BATT INSULATION
5/8" TYPE X FIRE-RATED GYP. SHEATHING
NOTE #1 AND #2.
1/2" AIR GAP
5/8" TYPE X FIRE-RATED GYP. SHEATHING
NOTE #1 AND #2.
SHEATHING
2 X 4 WOOD STUDS 16" O.C.
FULL THICKNESS SOUND ATTENUATING
BATT INSULATION
5/8" TYPE X FIRE-RATED GYP. BD.

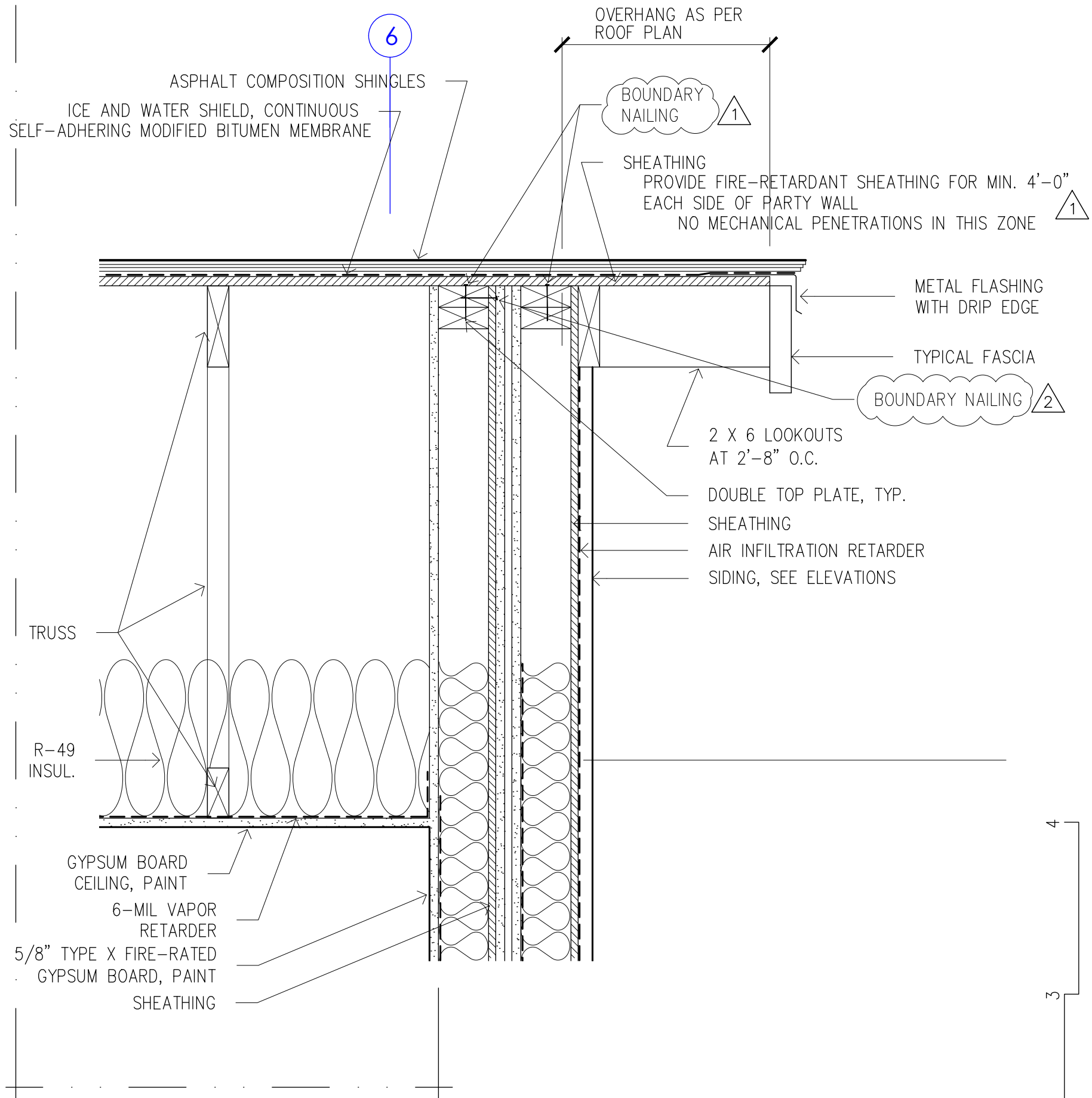

NOTES
1. AT GYPSUM SHEATHING LAYERS AT MIDDLE OF PARTY WALL, PROVIDE "FLAME FIGHTER FIRE TAPE" BY E-Z TAPING SYSTEM AT ALL PANEL JOINTS.
2. COORDINATE INSPECTIONS AS REQUIRED PRIOR TO CONCEALING CONSTRUCTION.

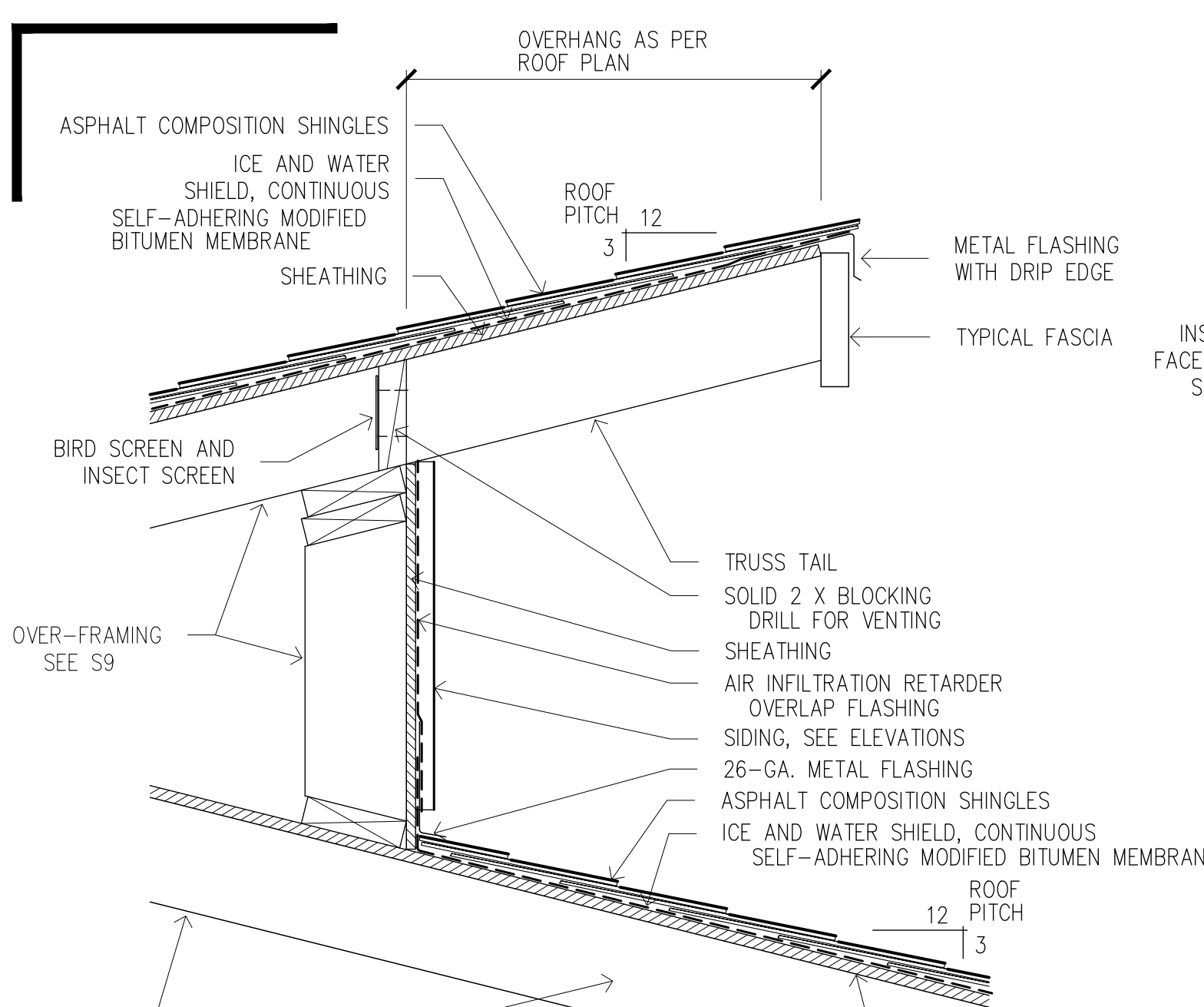

Ridge/Headwall 11
SEE DTL. 11/S9 FOR ADDITIONAL INFORMATION

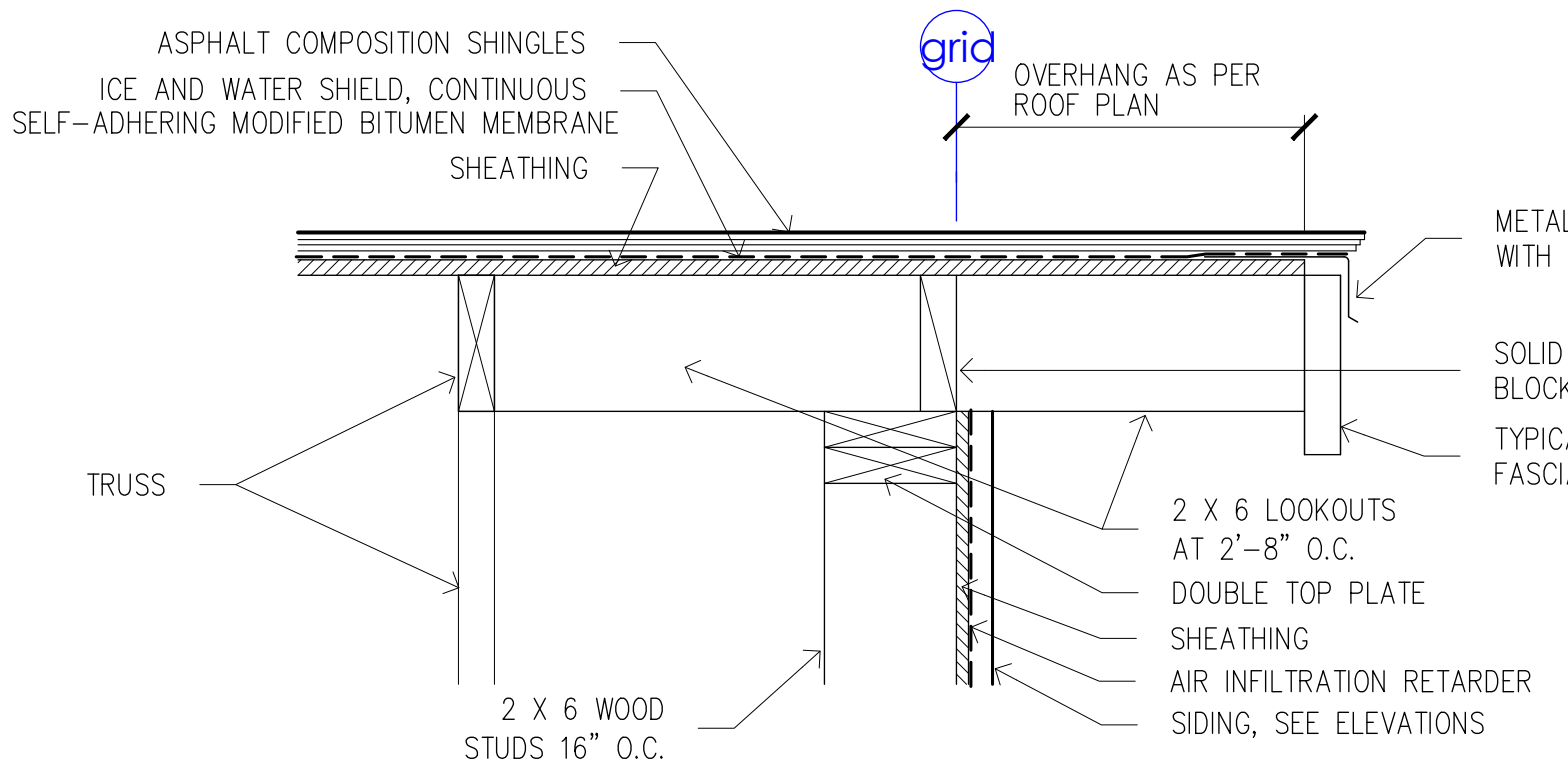

Typical Rake 10
SEE DTL. 10/S9 FOR ADDITIONAL INFORMATION

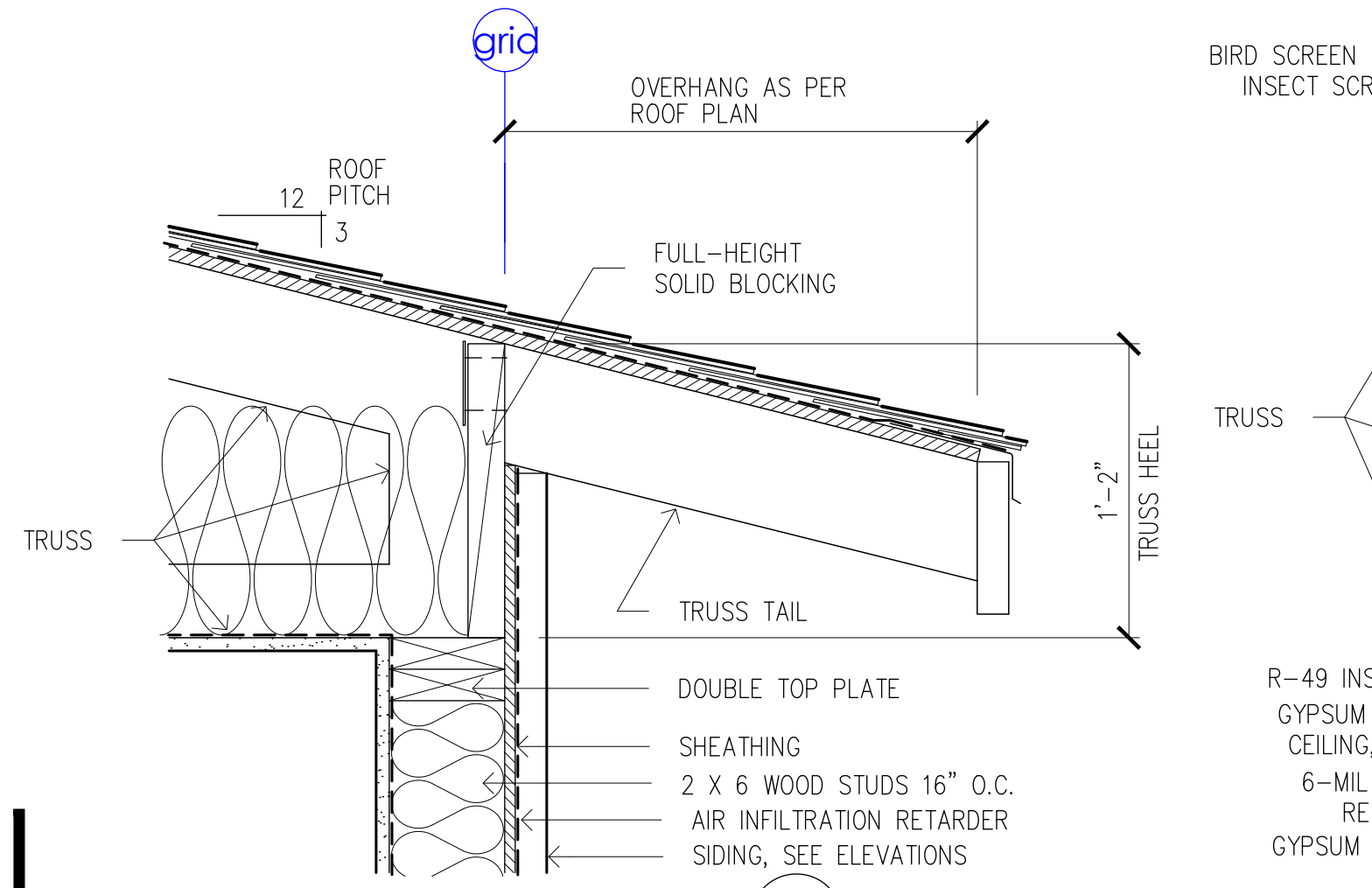

Eave 9
SEE DTL. 9/S9 FOR ADDITIONAL INFORMATION

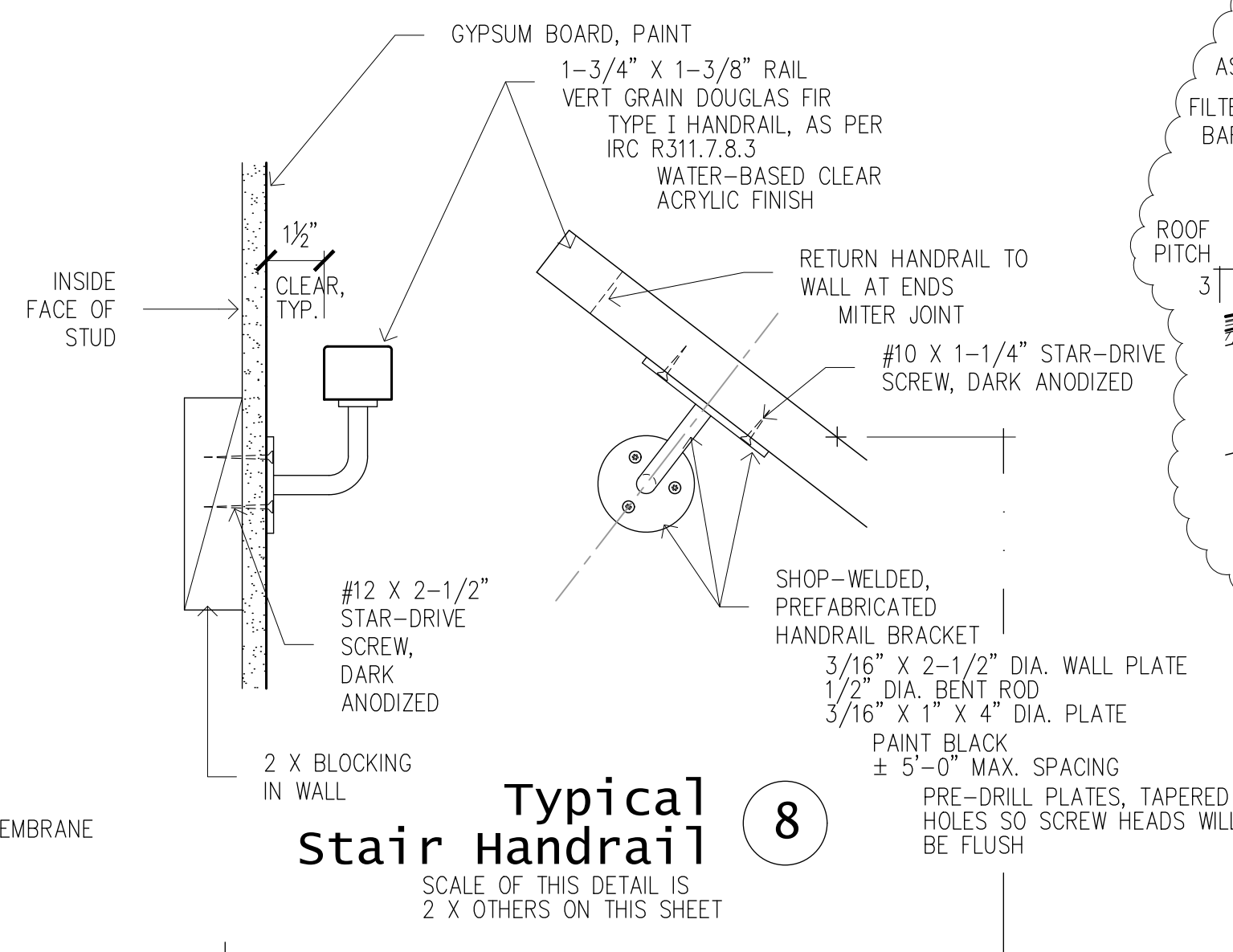

Typical stair Handrail 8
SCALE OF THIS DETAIL IS 2 X OTHERS ON THIS SHEET

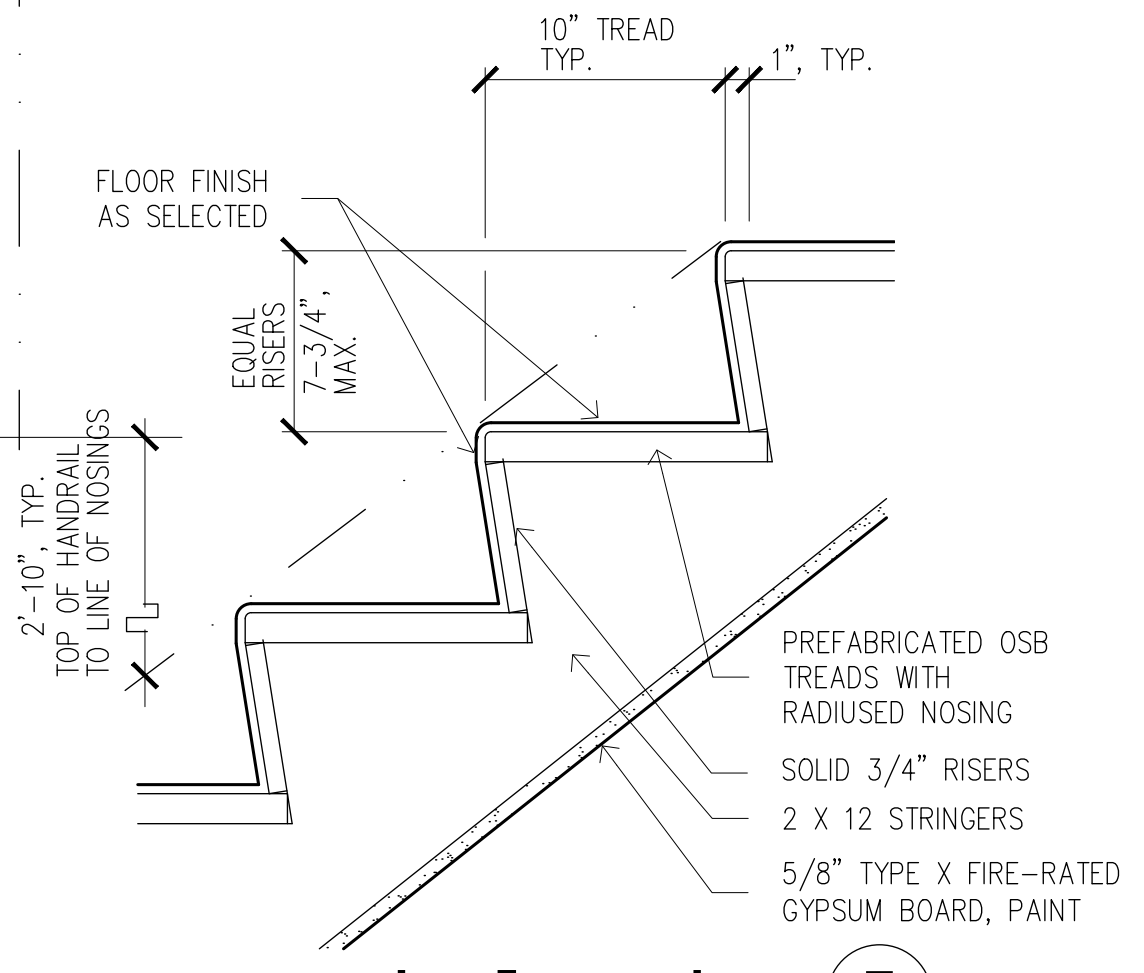

Typical stairs 7

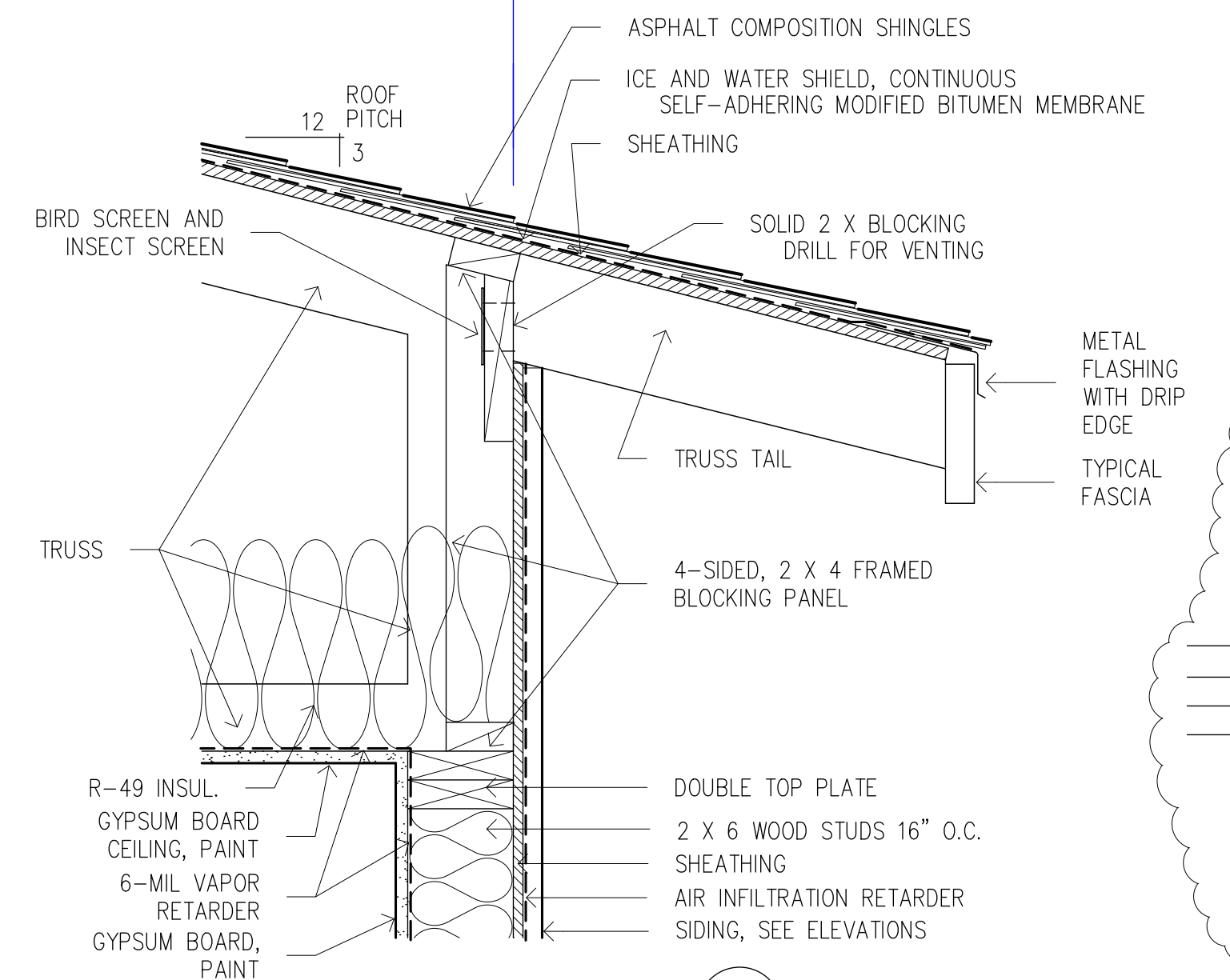

Eave 6
SEE DTL. 6/S9 FOR ADDITIONAL INFORMATION

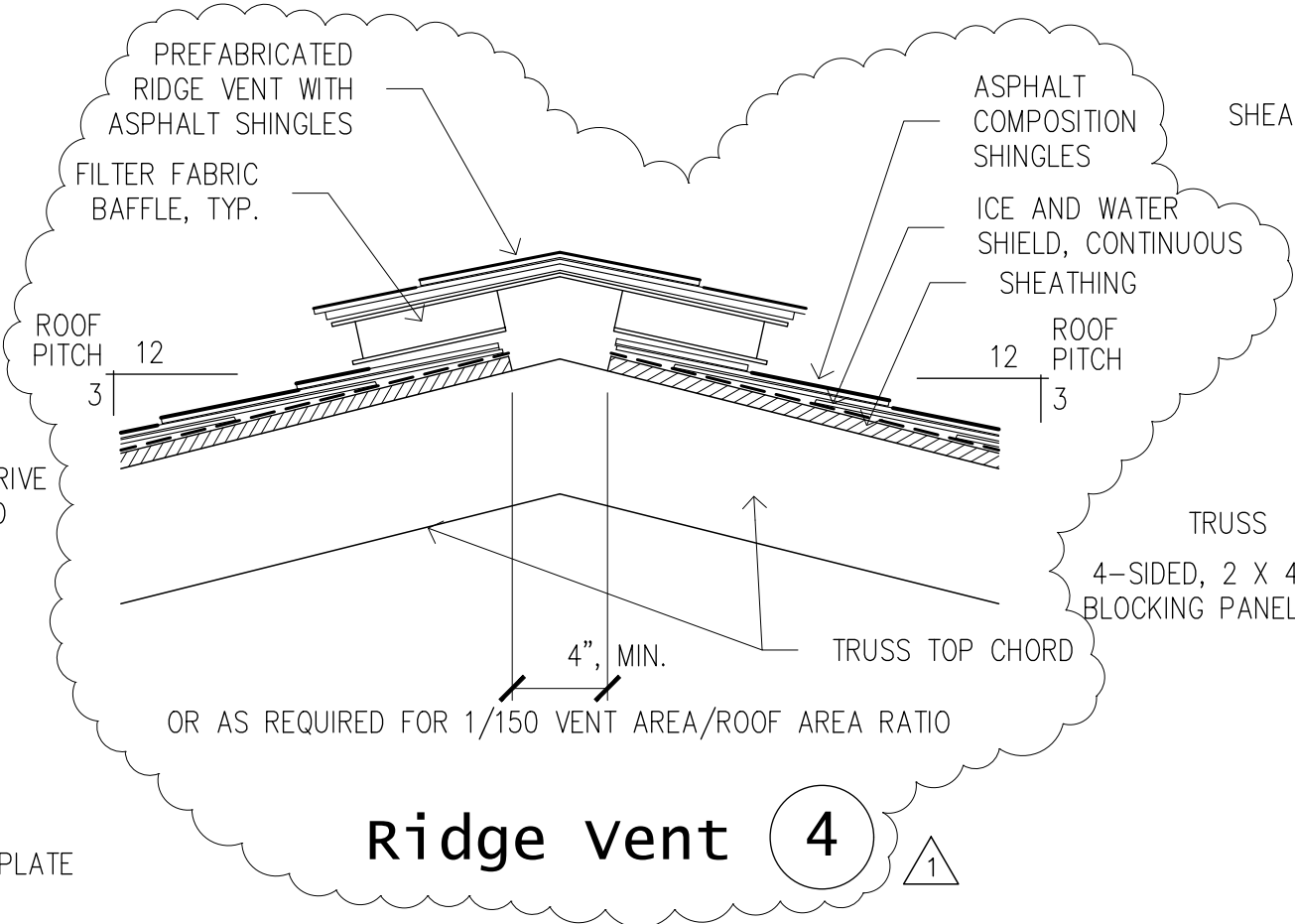

Ridge Vent 4

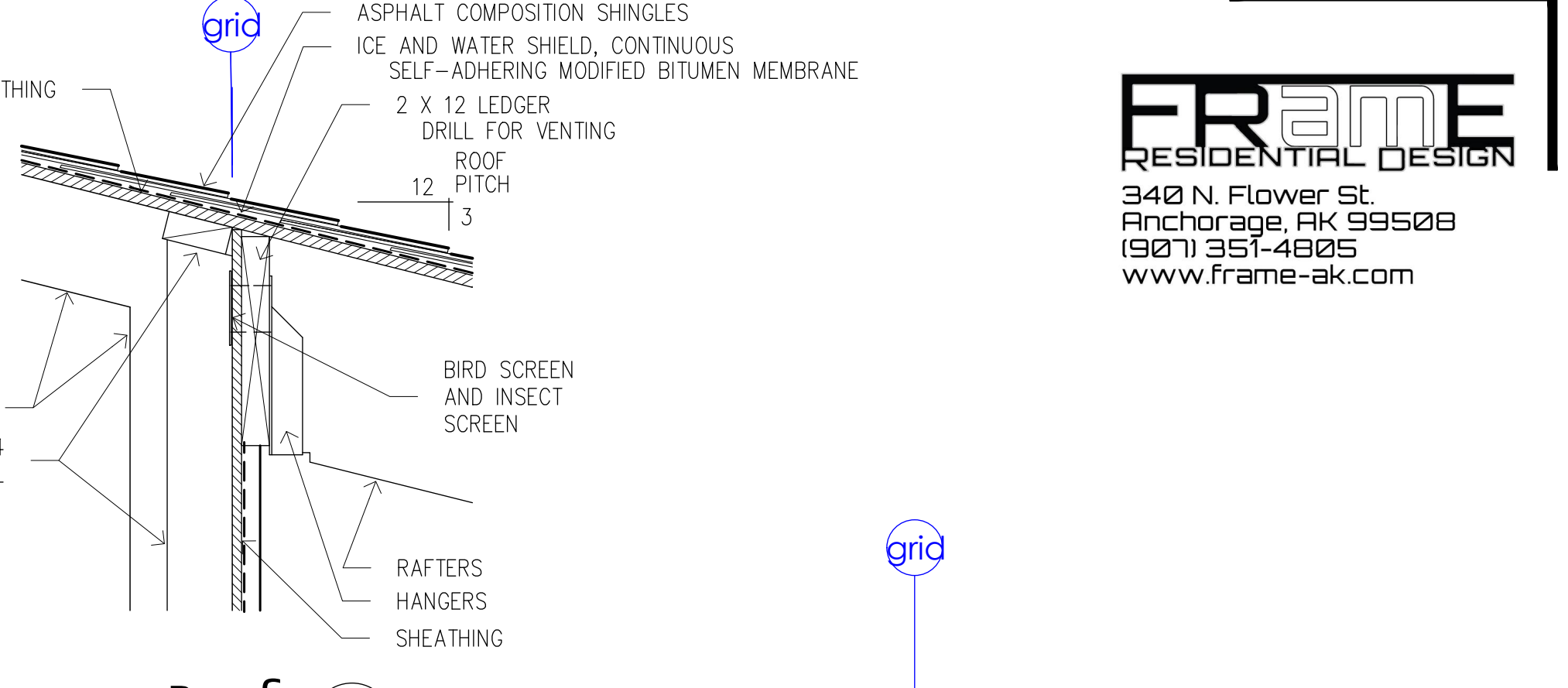

Roof Transition 5
SEE DTL. 5/S9 FOR ADDITIONAL INFORMATION

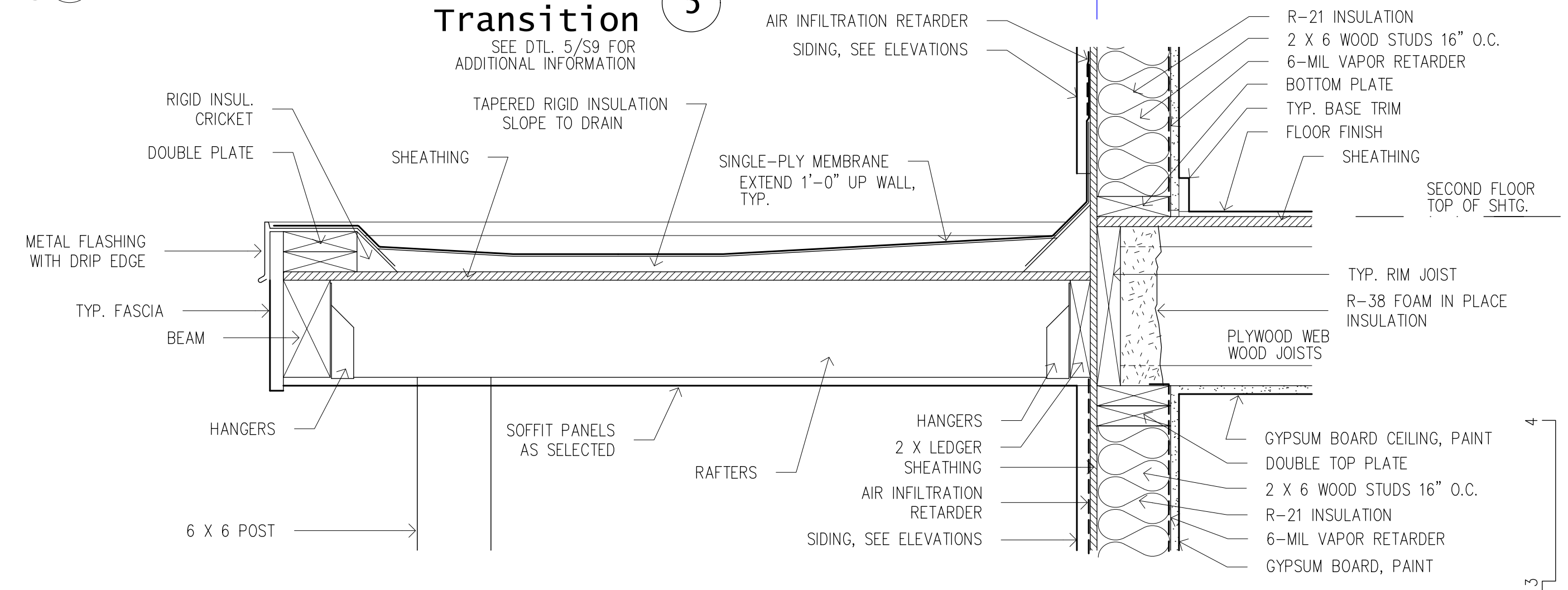

Back Porch Canopy Roof 3
SEE DTL. 3/S9 FOR ADDITIONAL INFORMATION

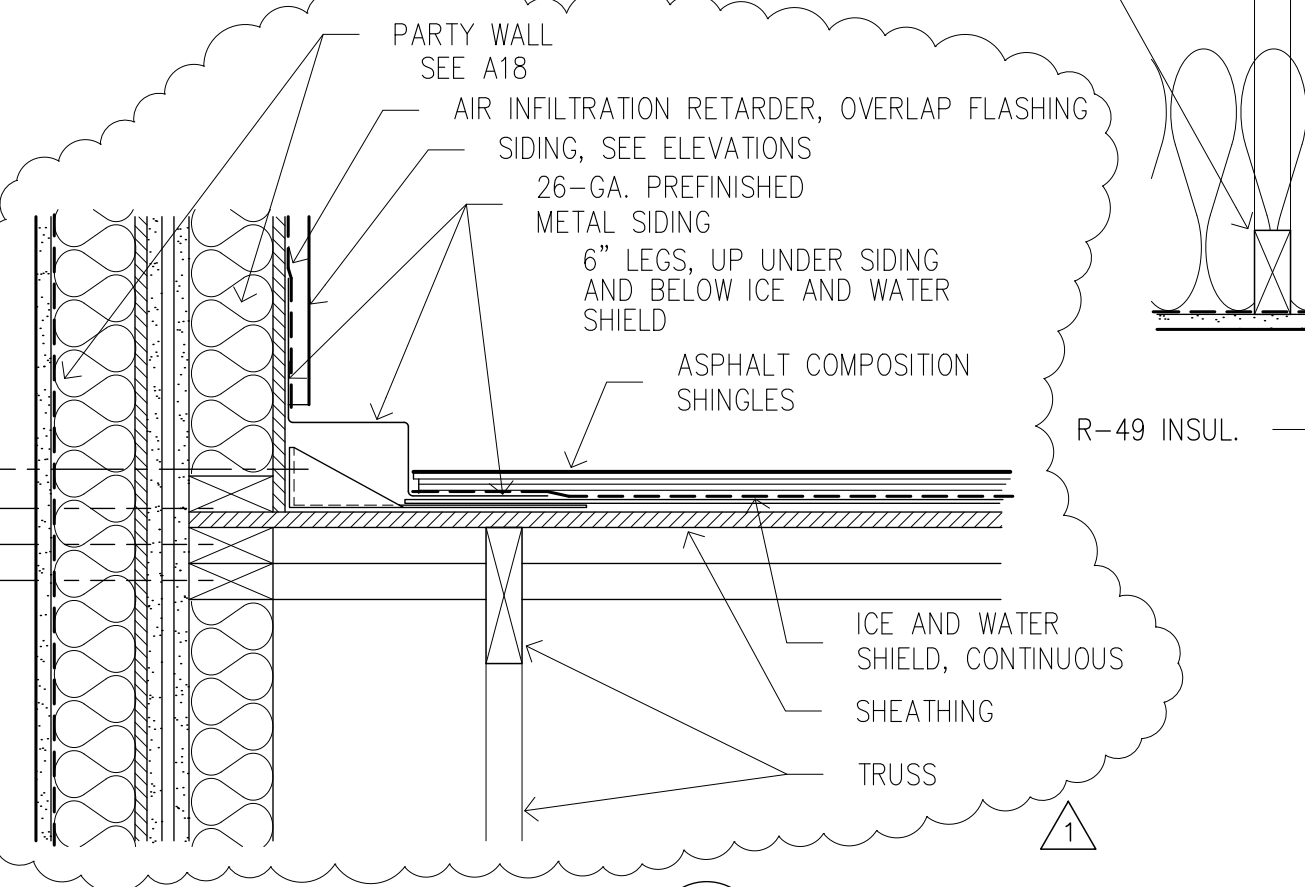

Drag Assembly 2
SEE DTL. 2/S9 FOR ADDITIONAL INFORMATION

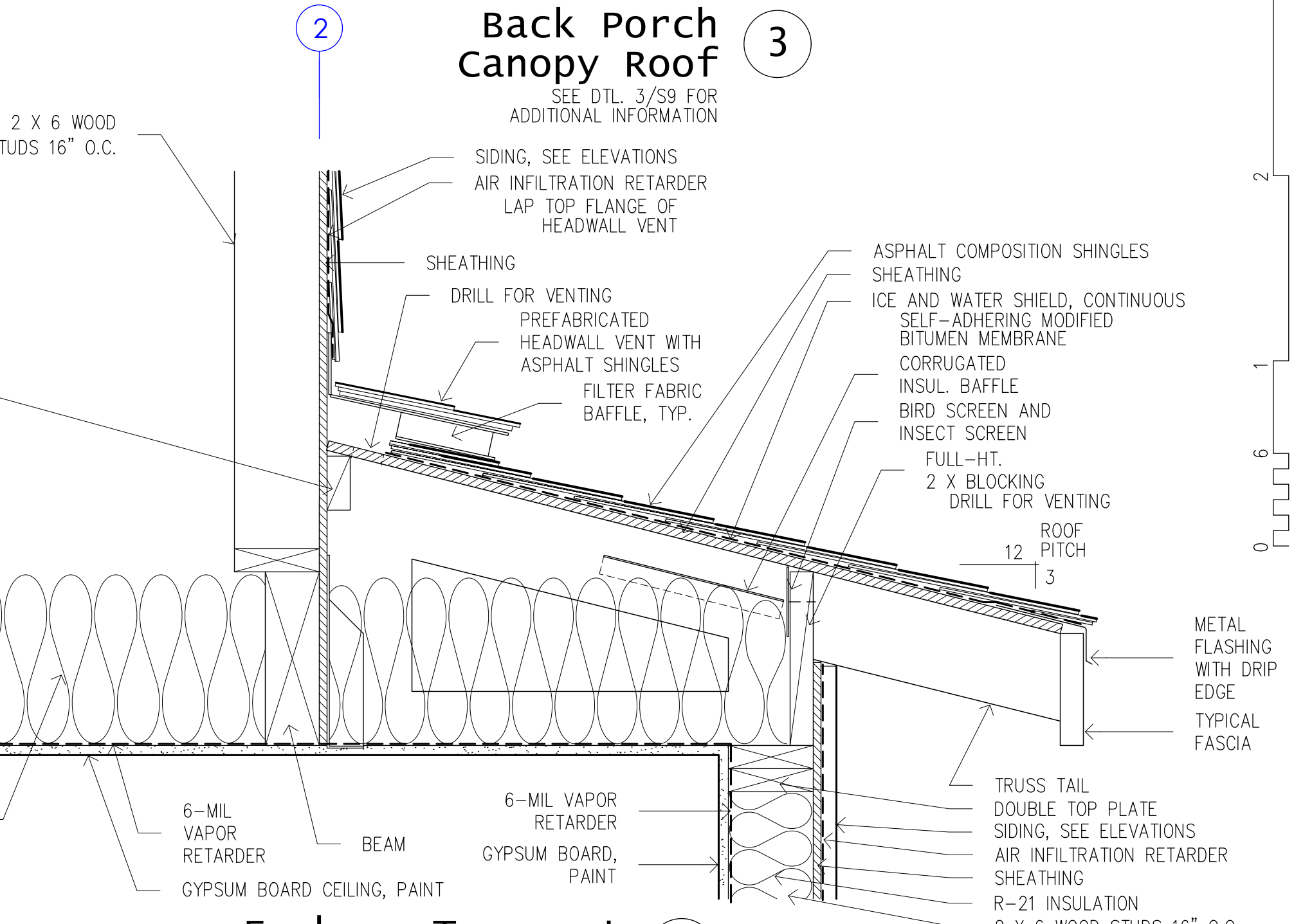

Eyebrow Truss at Bedroom Pop-Out 1
SEE DTL. 1/S9 FOR ADDITIONAL INFORMATION

Design Criteria

IBC 2018

WIND	
Basic Speed (3 sec gust)	155 mph (east side of Baxter Rd.)
Exposure	B
Pressures	ASCE 7-16
Risk Category	III
Int pressure Coeff	.18 (+/-)

Wind Load Analysis MWFRS (ANY HT)

SEISMIC	
Base shear =	.019 * W _s ASD S _{ds} = 1.200
Risk Category	II SD1 = 0.700
Design Category	D SS = 1.500
Site Class	D assumed S1 = 0.682
R =	6.5 IS = 1.0
	Fa = 1.2

Seismic Load Analysis Equivalent lateral force

SNOW	
Roof Snow, P _f	40 psf ASCE 7-16
Ground Snow, P _g	50 psf ASCE 7-16
Exposure Factor, C _e	1.0
Thermal Factor, C _t	1.1
Importance Factor, I _s	1.0

LOADS	
Snow	40 psf
Snow Seismic	8 psf
Roof Dead	15 psf
Roof Live	20 psf
Floor Dead	12 psf
Floor Live	40 psf
Exterior Walls	10 psf
Interior Walls	8 psf
CMU Foundation	85 psf
Concrete Foundation	100 psf

SOILS
Soil bearing strength assumed to be 1,500 psf, with 1/3 increase for seismic or wind loads, unless noted otherwise.

LATERAL LOAD RESISTING SYSTEM
Light frame walls with wood shear panels.

Nail Size Table

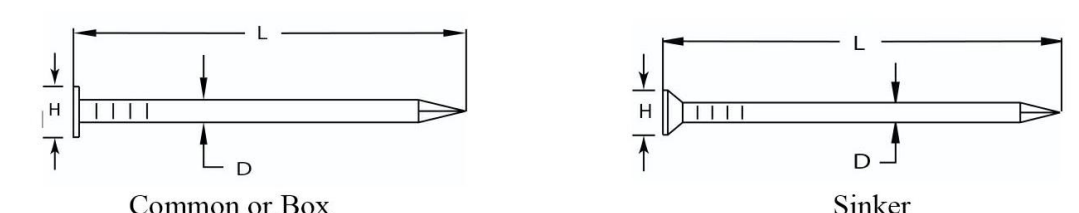

Type	Pennyweight											
	6d	7d	8d	10d	12d	16d	20d	30d	40d	50d	60d	
Common	L	2"	2-1/4"	2-1/2"	3"	3-1/4"	3-1/2"	4"	4-1/2"	5"	5-1/2"	6"
	D	0.113"	0.113"	0.131"	0.148"	0.148"	0.162"	0.192"	0.207"	0.225"	0.244"	0.263"
	H	0.266"	0.266"	0.281"	0.312"	0.312"	0.344"	0.406"	0.438"	0.469"	0.5"	0.531"
Box	L	2"	2-1/4"	2-1/2"	3"	3-1/4"	3-1/2"	4"	4-1/2"	5"	-	-
	D	0.099"	0.099"	0.113"	0.128"	0.128"	0.135"	0.148"	0.148"	0.162"	-	-
	H	0.266"	0.266"	0.297"	0.312"	0.312"	0.344"	0.375"	0.375"	0.406"	-	-
Sinker	L	1-7/8"	2-1/8"	2-3/8"	2-7/8"	3-1/8"	3-1/4"	3-3/4"	4-1/4"	4-3/4"	-	5-3/4"
	D	0.092"	0.099"	0.113"	0.12"	0.135"	0.148"	0.177"	0.192"	0.207"	-	0.244"
	H	0.234"	0.250"	0.266"	0.281"	0.312"	0.344"	0.375"	0.406"	0.438"	-	0.5"

Structural Notes

- Soils:**
- Allowable bearing strength assumed to be 1500 psf, with 33% increase for seismic or wind loads
- Concrete:**
- Portland cement concrete to have minimum 28 day compressive strength, $f_c = 3000$ psi. 5 sack (minimum) design mix with type II or type II Portland cement. Maximum aggregate size 3/4".
 - Concrete reinforcement to be ASTM A615, grade 60, deformed bars. Min rebar lap splices 40 bar diameters.
- CMU:**
- Masonry units to be ASTM C90, normal weight, fully grouted and reinforced per #3 below.
 - All masonry shall be solid grout, Type M or S Mortar and mechanically consolidated.
 - Reinforcing to be as shown on drawings. Minimum reinforcement shall be #5 at 32" OC; #5 at 48" OC, and #5 in top course. Vertical reinforcement to have standard hook. Reinforcement to be ASTM A615, grade 60, deformed bars. "Wet" setting reinforcement is prohibited. Lap splices 25 bar diameter, min.
 - $f_m = 2500$ psi
- Wood:**
- Framing lumber DF #2 or btr; Bottom Plates at concrete trt'd #2 DF
 - Truss lumber Doug-Fir, size and grade selected by designer.
 - Blocking not required roof / floor diaphragms UNO; boundary nail roofs at 3" OC, panel edges at 4" OC, and field at 8" OC. Boundary nail floors at 4" OC, panel edges at 4" OC, and field at 12" OC.
 - Shear wall/roof diaphragm/floor diaphragm nailing specified refers to panel edge and boundaries; field fasten at 12" O.C., floors and walls. Field fasten roofs at 8" OC, UNO.
 - Multiple stud splices- use two rows 16d com @ 6" OC, min.
 - Multiple LVL - splice w/ 2 rows 16d com @ 6" OC, 2" from top and 2" from bottom.
 - 3" members required at abutting panel joints and nails shall be staggered where nail spacing is 2" OC and where 10d nails penetrating more than 1 1/2" are placed at 3" or less OC. 3" bottom plates are required where unit shear loads exceed 600 plf.
 - Glulam members: single span- rated 24F-V4, DF/DF; multiple span - rated 24F-V4, DF/DF UNO.
 - APA rated sheathing required for shear walls, floor and roof diaphragms. Wall sheathing may be installed horizontally or vertically. Block all panel edges.
 - Where T-111 siding is used for shear sheathing, minimum thickness shall be 19/32". All nailing must be through full thickness. Block all joints if full height siding is not used.
 - Fastener & diaphragm values per NDS SDPWS 15, DF #2.
 - Plywood may be substituted for OSB, same APA rating.
 - Use APA rated sheathing as follows, unless noted otherwise:
Shear walls and roofs - non drift areas 24/16.
Roofs - valleys and upper drift areas 32/16.
Roofs, below upper roofs and where wall causing drifts is 6' or higher 40/20.
 - See schedule for nail diameter and length
 - Anchor bolts per schedule; all else IBC minimum 5/8" by 12" at 4'-0" O.C. 7" embedment, min.
 - Holdowns & anchor bolts shown are Simpson or as approved by MOA.
 - Holdown values per Simpson DF tables.
 - GWB per IBC minimum; not used for shear.
 - Hangers, straps, saddles, and other hardware are as manufactured by Simpson Strongtie, DF #2 loading.
- Steel:**
- Plate, channel, angle - ASTM A36; Wide Flange - ASTM A992, Gr 50
 - Anchor bolts and machine bolts - ASTM A307, ASTM A1554
 - HSS - [round, square, rectangular sections] ASTM A500 grade B F_y = 46ksi
 - Pipe - ASTM A53 grade B F_y = 35 ksi

Shear Wall Design Values

(Doug Fir, 2015 NDS SDPWS)

Wall	Vall ⁶	Sheathing	Studs	Members with abutting panels	Nails		
					Boundary nail	Field nail	Btm. plate attach.
N1	393	7/16" OSB, one side	2x at 16" o.c.	(1) 2x	.131 x 2-1/2" at 4" o.c.	.131 x 2-1/2" at 12" o.c.	.148 x 3" at 4" o.c.
N2	505	7/16" OSB, one side	2x at 16" o.c.	3x or (2) 2x stitch with (2) 16d at 4"	.131 x 2-1/2" at 3" o.c.	.131 x 2-1/2" at 12" o.c.	.148 x 3" at 3" o.c.
N3	655	7/16" OSB, one side	2x at 16" o.c.	3x or (2) 2x stitch with (2) 16d at 4"	.131 x 2-1/2" at 2" o.c.	.131 x 2-1/2" at 12" o.c.	.148 x 3" at 2" o.c.
N4	786	7/16" OSB, two sides	2x at 16" o.c.	3x or (2) 2x stitch with (2) 16d at 4"	.131 x 2-1/2" at 4" o.c.	.131 x 2-1/2" at 12" o.c.	.148 x 3" at 2" o.c.
N5	1010	7/16" OSB, two sides	2x at 16" o.c.	3x or (2) 2x stitch with (2) 16d at 4"	.131 x 2-1/2" at 3" o.c.	.131 x 2-1/2" at 12" o.c.	.161 x 3" at 2" o.c.
N6	1311	7/16" OSB, two sides	2x at 16" o.c.	3x or (2) 2x stitch with (2) 16d at 4"	.131 x 2-1/2" at 2" o.c.	.131 x 2-1/2" at 12" o.c.	Dbl. rim, two rows .148 x 3" at 2-1/2"
N7	1457	15/16" OSB, two sides	2x at 16" o.c.	3x or (2) 2x stitch with (2) 16d at 3"	.131 x 2-1/2" at 2" o.c.	.131 x 2-1/2" at 12" o.c.	Dbl. rim, two rows .161 x 3" at 2"
N8	1949	19/32" OSB, two sides	2x at 16" o.c.	3x or (2) 2x stitch with (2) 16d at 3"	.131 x 2-1/2" at 2" o.c.	.131 x 2-1/2" at 12" o.c.	Dbl. rim, two rows SDS1/4 x 3 at 4"

- 3 x (2-2x) members are required at abutting panel edges where spacing is 2" o.c. and where 10d nails penetrating more than 1-1/2" into receiving member are spaced at 3" o.c. or less. Framing members in walls with shears > 350 plf with abutting panels receiving edge nailing shall be 3x (2-2x). 2x sill plates may be used for wall shears > 350 plf and < 600 plf if anchor bolt spacing is one-half that required by the design.
- Offset stagger nails from side to side for double sheathing. Provide two rows nails, staggered where 2" o.c. nailing occurs. Block all sheathing edges. Install sheathing horizontally or substitute 15/32" sheathing for 7/16" sheathing.
- Bottom plate attachment assumes solid members below.
- Where bottom plates rest directly on concrete or masonry, anchor bolt schedule supercedes bottom plate fastening schedule. 5" x 5" x 1/4" washers are required at all sill anchor bolts. 3x (2-2x) sill plates are required where shears > 700 plf. Stitch plates with (2) 16d at 3" o.c., staggered. Where bottom plates of two-sided shear wall rest directly on concrete or masonry, use 3x sill plate, per Municipality of Anchorage amendments.
- Values are DF framing per SDPWS-15, Table 4.3A, adjusted per 4.3.3, ASD, seismic, where $Vall = [Vnom/2]^{1.5}$.
- Multiple stud splices - use two rows 16d com at 6" o.c., min.

Anchor Bolts

Call-out	Anchor bolt	at	Spacing
①	5/8" x 12"	at	48" o.c.
②	5/8" x 12"	at	36" o.c.
③	5/8" x 12"	at	32" o.c.
④	5/8" x 12"	at	24" o.c.
⑤	5/8" x 12"	at	16" o.c.
⑥	5/8" x 12"	at	12" o.c.

Hold Downs

HOLDOWNS

CALL-OUT	STRAP or HOLDOWN	CHORD	ANCHOR BOLT	EMBED. MASONRY	EMBED. CONCRETE	ALLOWABLE LOAD (Lbs)
①	(1) - MST 37	(2) - 2x				2,828
②	(1) - MST48	(2) - 2x				4,073
③	(1) - MST 60	(2) - 2x				5,200
④	(1) - MST 72	(2) - 2x				5,800
⑤	(2) - MST 48	(4) - 2x				8,146
⑥	HDU2	(2) - 2x	5/8"	7" into ft'g. UNO	7" into ft'g. UNO	2,215
⑦	HDU4	(2) - 2x	5/8"	7" into ft'g. UNO	7" into ft'g. UNO	3,285
⑧	HDU5	(3) - 2x	5/8"	7" into ft'g. UNO	7" into ft'g. UNO	4,065
⑨	HDU8	(2) - 2x	7/8"	7" into ft'g. UNO	7" into ft'g. UNO	4,305
⑩	HDU8	(3) - 2x	7/8"	7" into ft'g. UNO	7" into ft'g. UNO	5,665
⑪	HDU11	(4) - 2x	1"	See Dtl's	See Dtl's	6,865
⑫	HDU11	(5) - 2x	1"	See Dtl's	See Dtl's	8,045
⑬	HDU14	(4) - 2x	1"	See Dtl's	See Dtl's	10,350
⑭	HD12	(3) - 2x	1 1/8"	See Dtl's	See Dtl's	11,055
⑮	HD12	(4) - 2x	1 1/8"	See Dtl's	See Dtl's	15,510
⑯	FSC	2x				1,570
⑰	MSTC48B3	2x				3,380
⑱	MSTC66B3	2x				3,820

Roof Design

See Sht. A9 for roof zone locations

Zone	Design Loads	Sheathing Index	Sheathing Nailing
1	TCLL - 40 psf TCDL - 15 psf BCDL - 5 psf	APA 24/16	BN - 8d common at 3" o.c.
			EN - 8d common at 3" o.c. FN - 8d common at 8" o.c.
2	TCLL - 65 psf TCDL - 15 psf BCDL - 5 psf	APA 32/16	BN - 8d common at 3" o.c.
			EN - 8d common at 3" o.c. FN - 8d common at 8" o.c.
3	TCLL - 85 psf TCDL - 15 psf BCDL - 5 psf	APA 40/20	BN - 8d common at 3" o.c.
			EN - 8d common at 3" o.c. FN - 8d common at 8" o.c.
4	TCLL - 105 psf TCDL - 15 psf BCDL - 5 psf	APA 40/20	BN - 8d common at 3" o.c.
			EN - 8d common at 3" o.c. FN - 8d common at 8" o.c.

BN = boundary nailing
EN = edge nailing
FN = field nailing

COOK INLET HOUSING AUTHORITY
BAXTER MULTIPLEXES, PHASE II
Tract B, valetskaya Addition No. 1
NHN Erna Court
ANCHORAGE, ALASKA

3/31/26
DR. BY: CLARK
DATE: 23 JAN 26

S1

20 of 28

FRAME
RESIDENTIAL DESIGN
340 N. Flower St.
Anchorage, AK 99508
(907) 351-4805
www.frame-ak.com



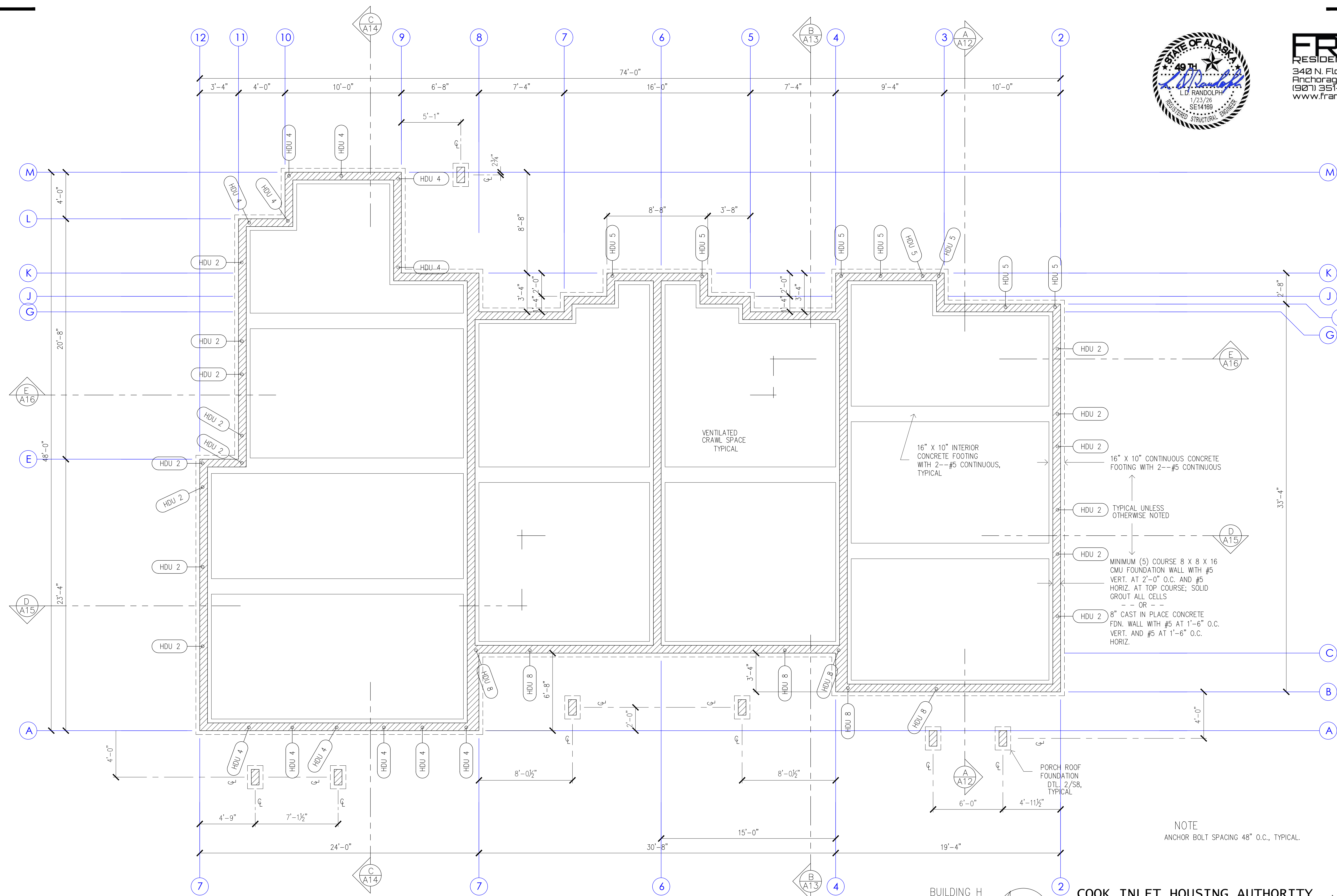

BUILDING H
Foundation Plan

**COOK INLET HOUSING AUTHORITY
BAXTER MULTIPLEXES, PHASE II
Tract B, valetskaya Addition No. 1
NHN Erna Court
ANCHORAGE, ALASKA**

3/31/26
DR. BY: CLARK
DATE: 23 JAN 26

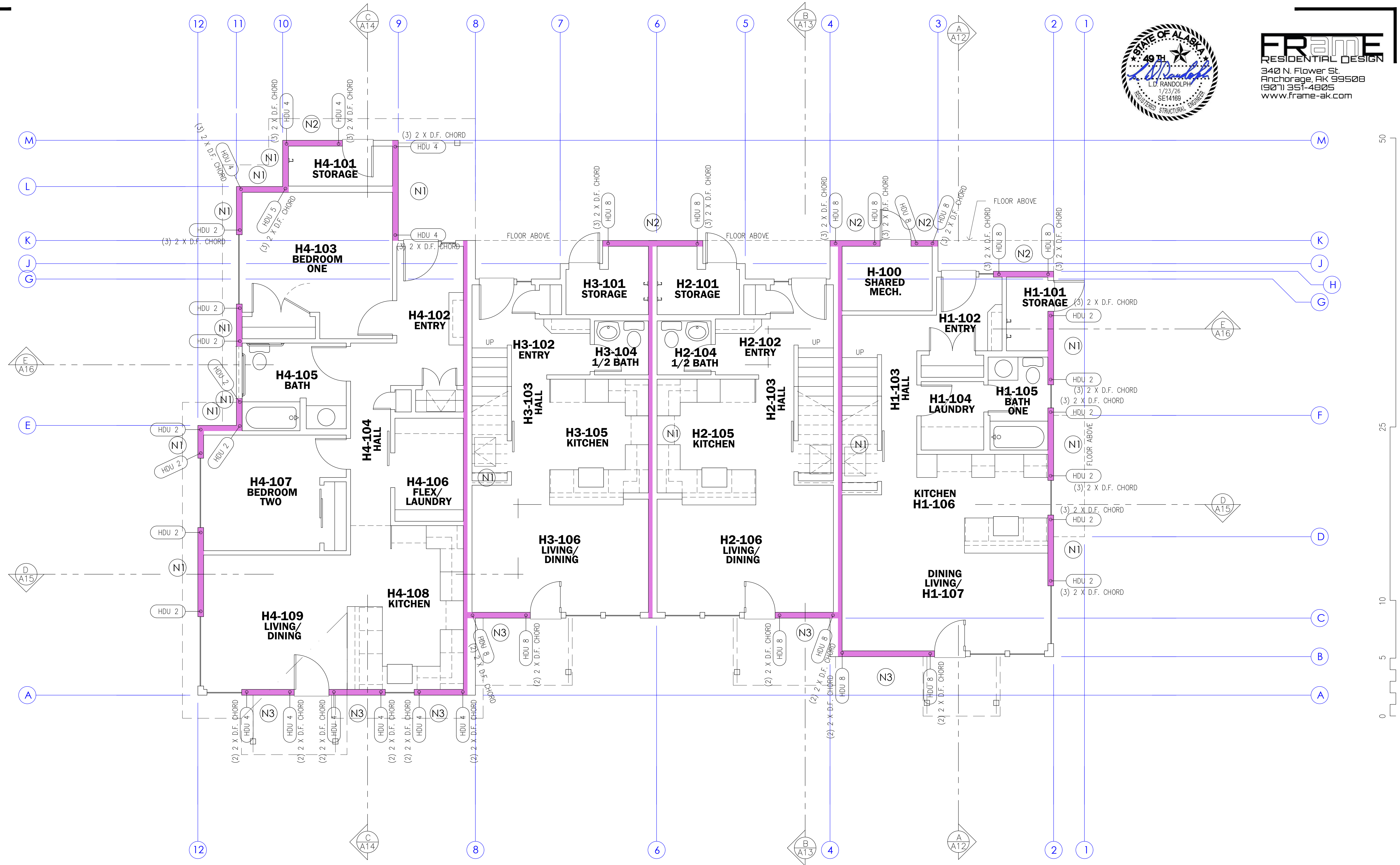
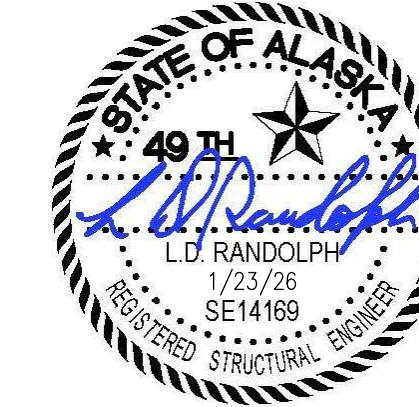

BUILDING H
First Floor
Shear wall Plan

COOK INLET HOUSING AUTHORITY
BAXTER MULTIPLEXES, PHASE II
Tract B, valetskaya Addition No. 1
NHN Erna Court
ANCHORAGE, ALASKA

3/31/26
DR. BY: CLARK
DATE: 23 JAN 26

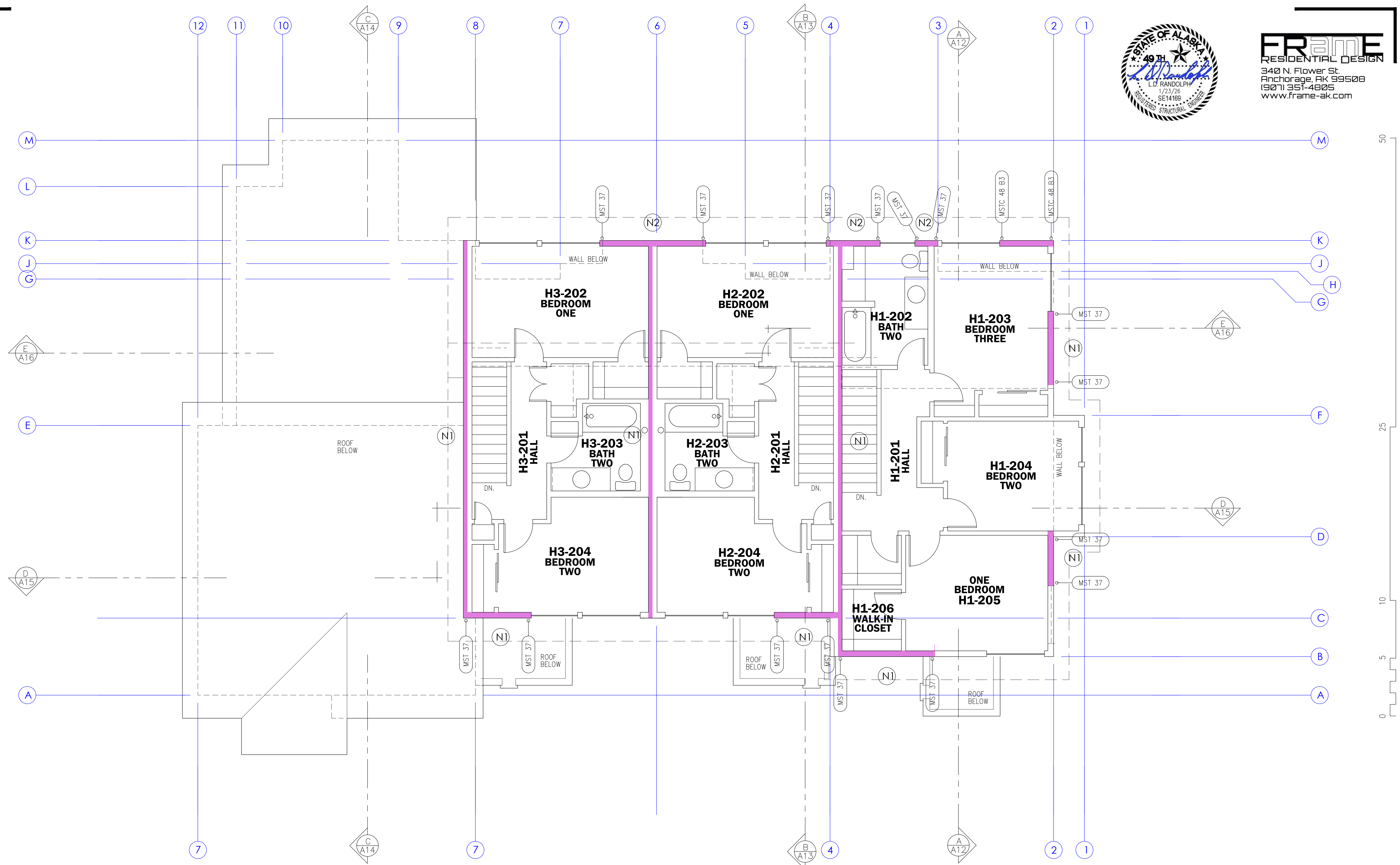

BUILDING H
Second Floor
Shear wall Plan

COOK INLET HOUSING AUTHORITY
BAXTER MULTIPLEXES, PHASE II
Tract B, valetskaya Addition No. 1
NHN Erna Court
ANCHORAGE, ALASKA

DR. BY: CLARK
DATE: 23 JAN 26

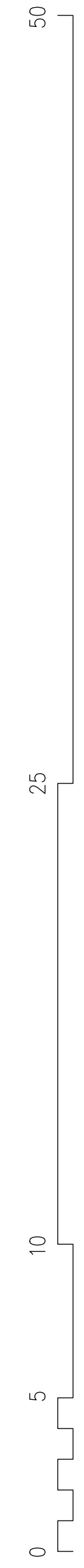
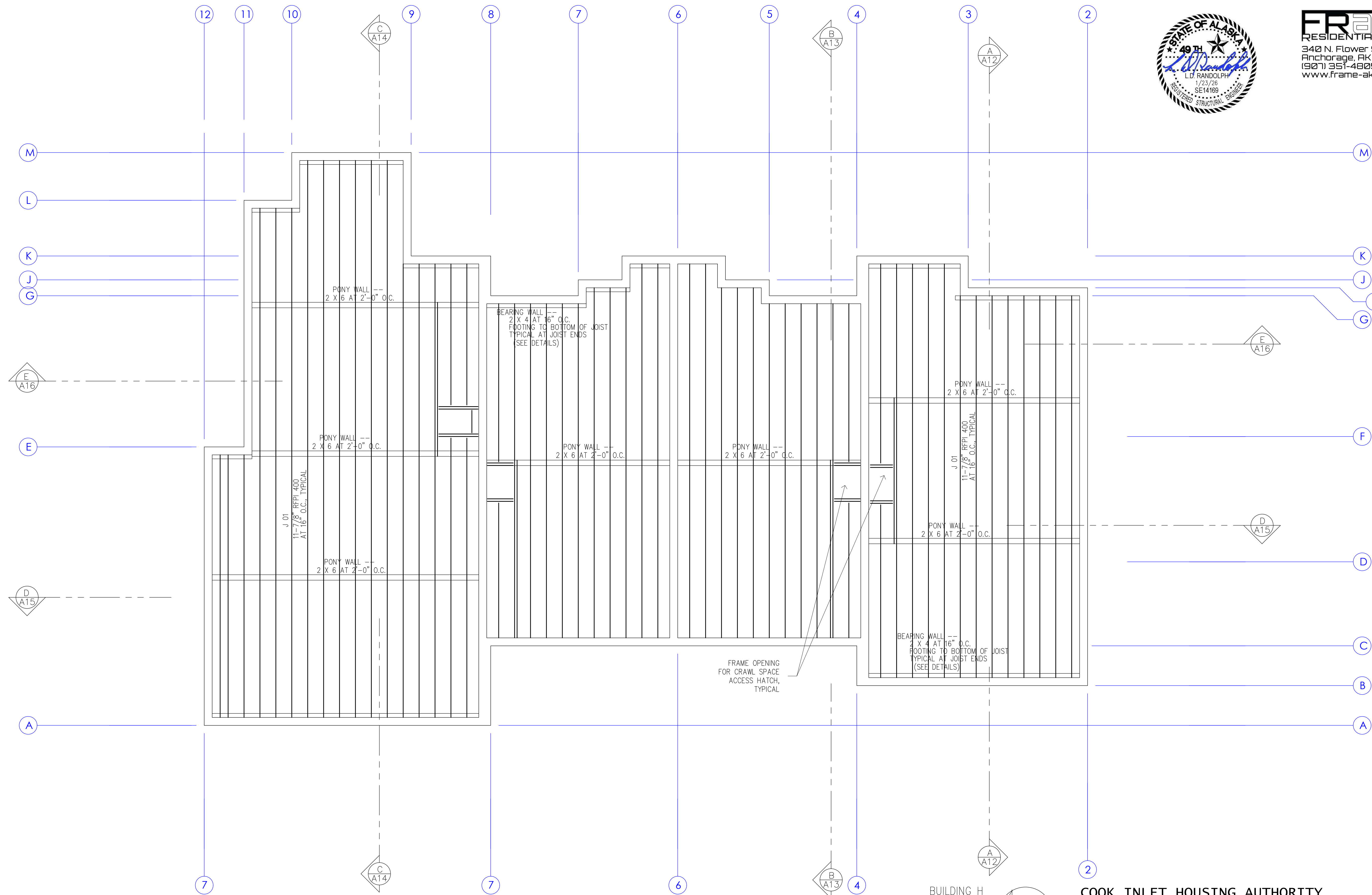

BUILDING H
First Floor Framing Plan

**COOK INLET HOUSING AUTHORITY
BAXTER MULTIPLEXES, PHASE II**
Tract B, valetskaya Addition No. 1
NHN Erna Court
ANCHORAGE, ALASKA

DR. BY: CLARK
DATE: 23 JAN 26

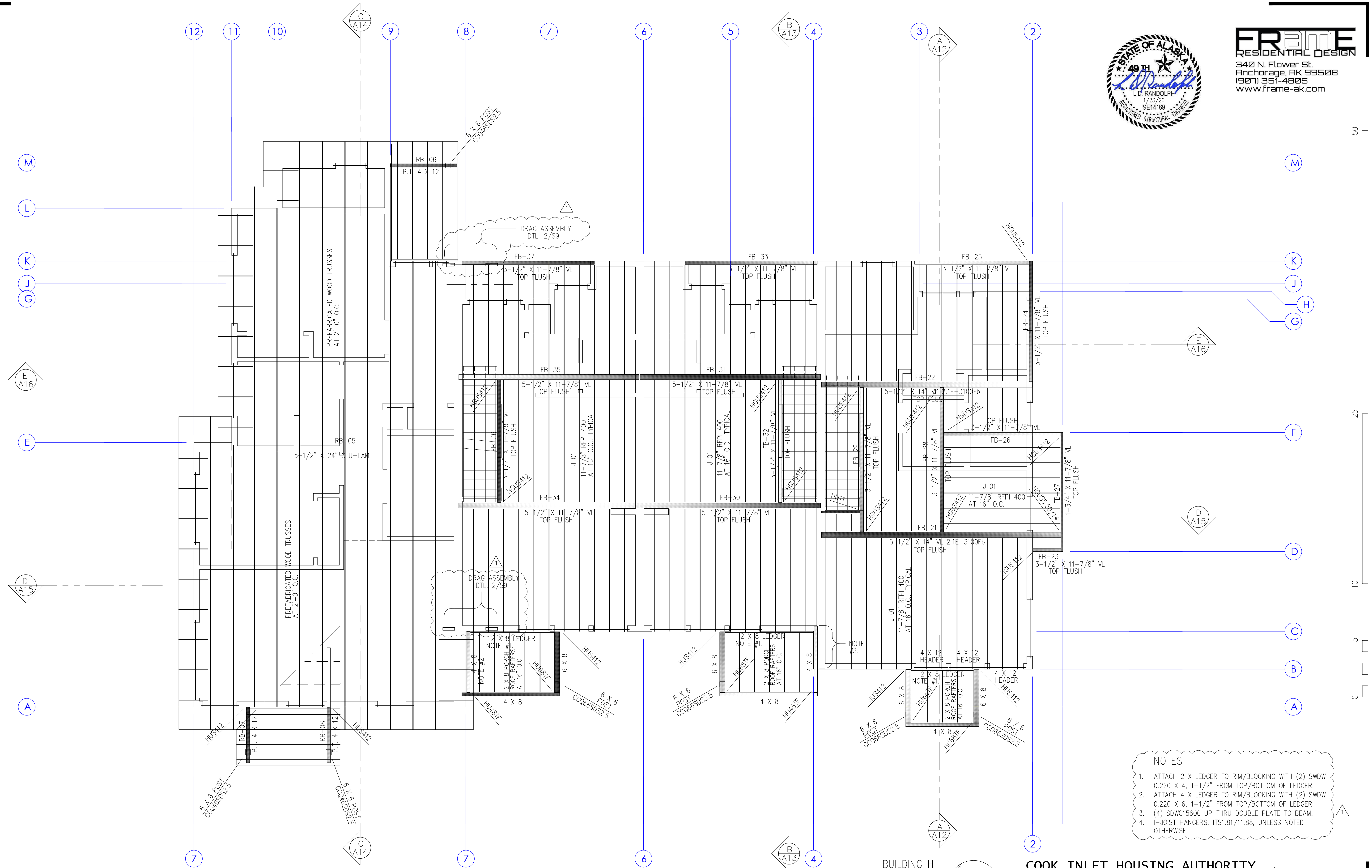

- NOTES**
1. ATTACH 2 X LEDGER TO RIM/BLOCKING WITH (2) SDW 0.220 X 4, 1-1/2" FROM TOP/BOTTOM OF LEDGER.
 2. ATTACH 4 X LEDGER TO RIM/BLOCKING WITH (2) SDW 0.220 X 6, 1-1/2" FROM TOP/BOTTOM OF LEDGER.
 3. (4) SDWC15600 UP THRU DOUBLE PLATE TO BEAM.
 4. I-JOIST HANGERS, ITS1.81/11.88, UNLESS NOTED OTHERWISE.

BUILDING H
**Second Floor/Low
Roof Framing Plan**

**COOK INLET HOUSING AUTHORITY
BAXTER MULTIPLEXES, PHASE II**
Tract B, valetskaya Addition No. 1
NHN Erna Court
ANCHORAGE, ALASKA

3/31/26
DR. BY: CLARK
DATE: 23 JAN 26

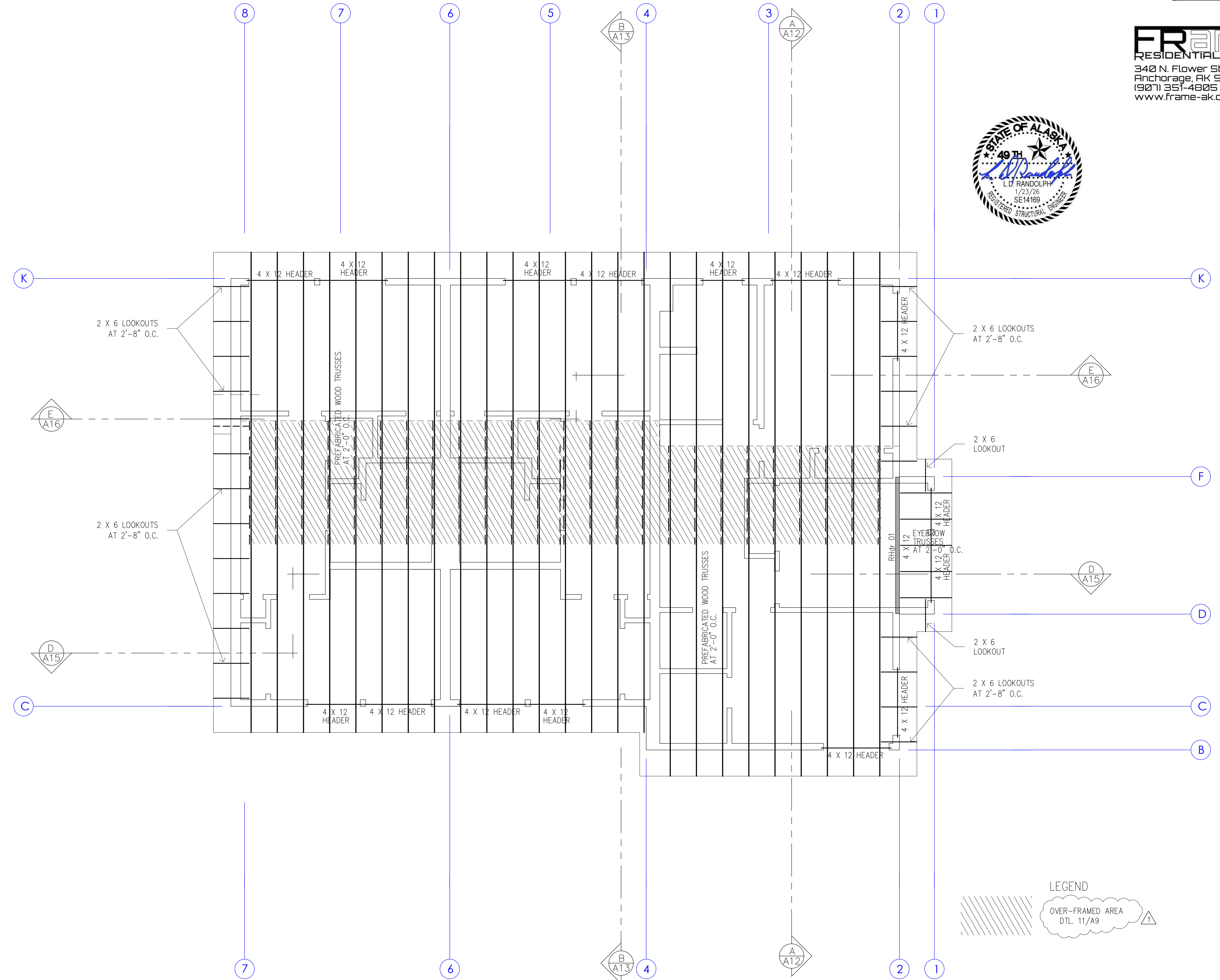
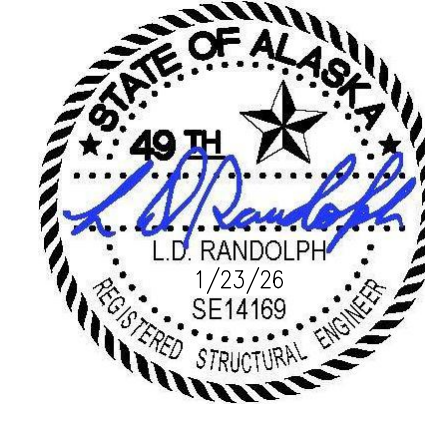

LEGEND
 OVER-FRAMED AREA
 DTL. 11/A9

BUILDING H
High Roof Framing Plan

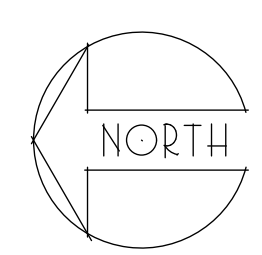

**COOK INLET HOUSING AUTHORITY
BAXTER MULTIPLEXES, PHASE II**
Tract B, valetkaya Addition No. 1
NHN Erna Court
ANCHORAGE, ALASKA

3/31/26
DR. BY: CLARK
DATE: 23 JAN 26

S7
26 OF 28

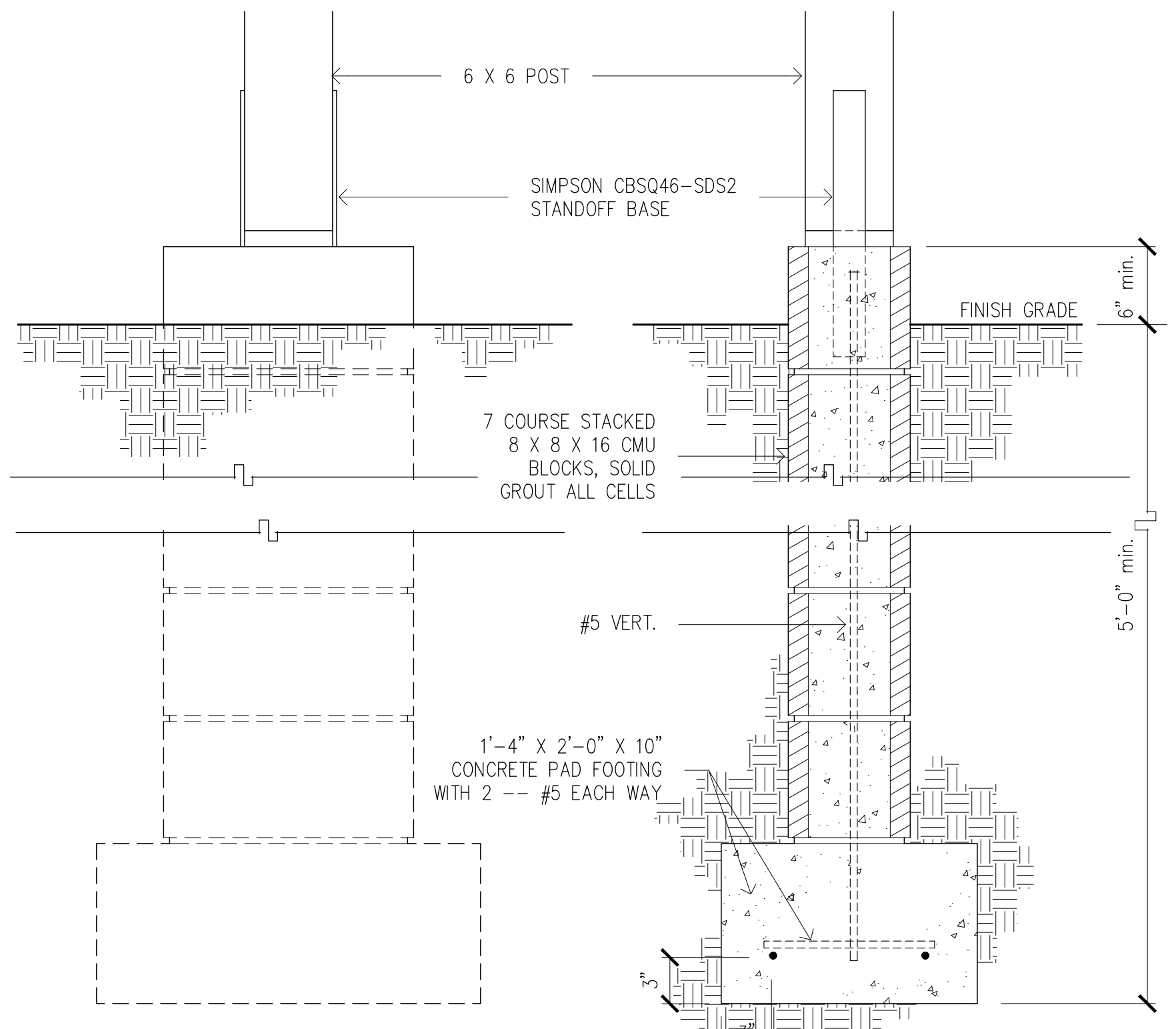

Porch Foundation 2

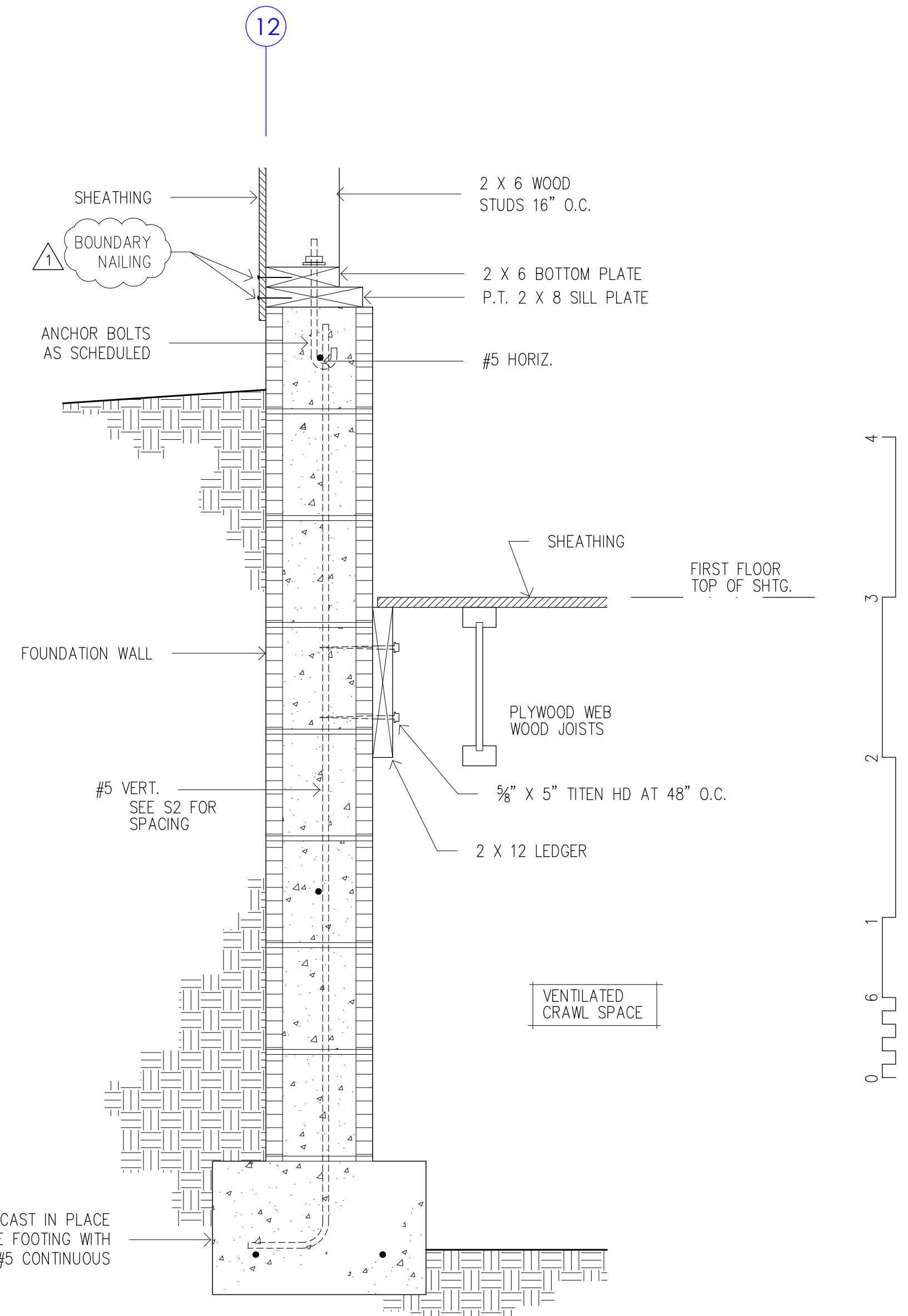

North wall Foundation 1

SEE DTL. 1/A17 FOR ADDITIONAL INFORMATION
**COOK INLET HOUSING AUTHORITY
BAXTER MULTIPLEXES, PHASE II
Tract B, valetskaya Addition No. 1
NHN Erna Court
ANCHORAGE, ALASKA**

3/31/26
DR. BY: CLARK
DATE: 23 JAN 26

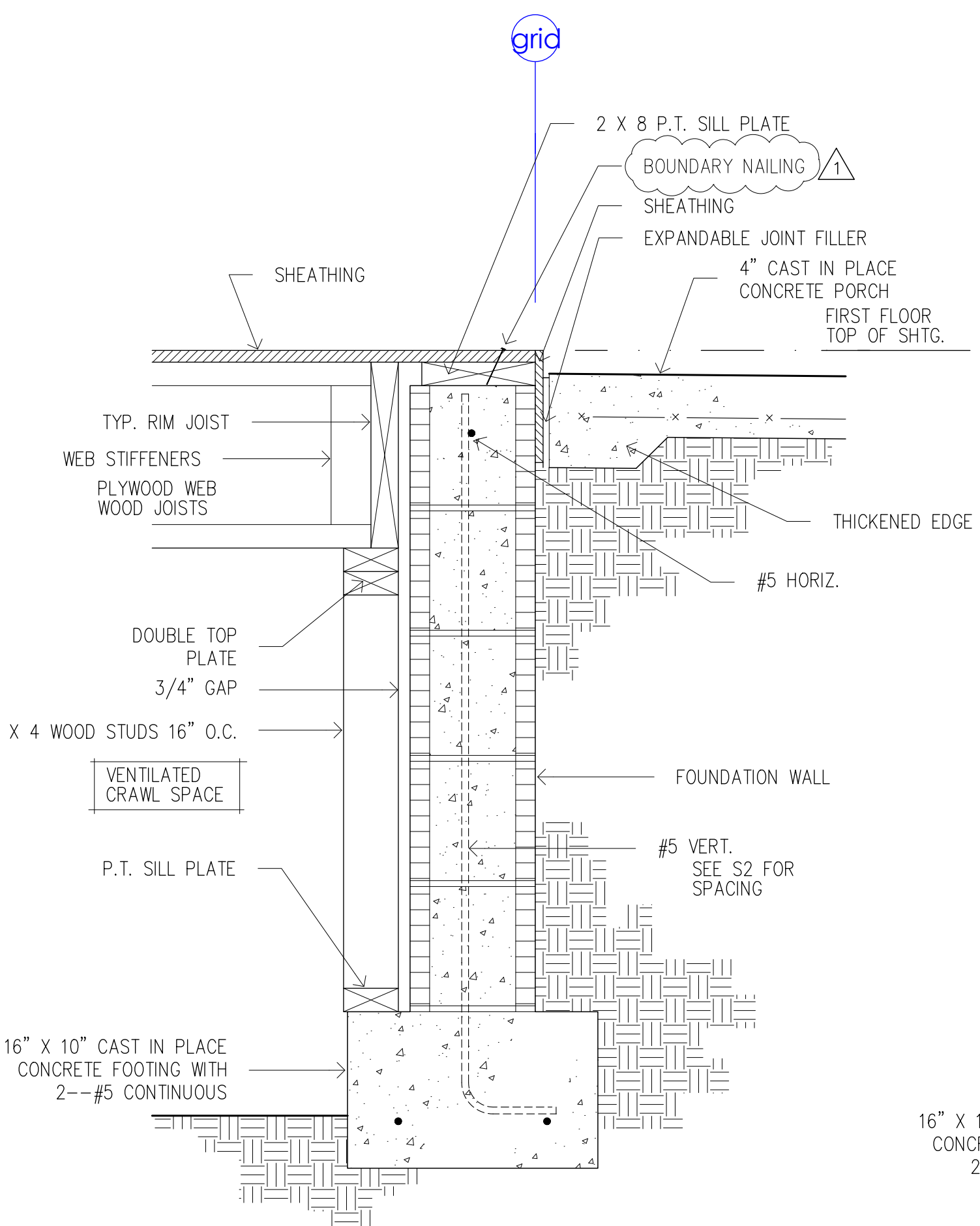

Typical Foundation wall 7
SEE DTL. 7/A17 FOR ADDITIONAL INFORMATION

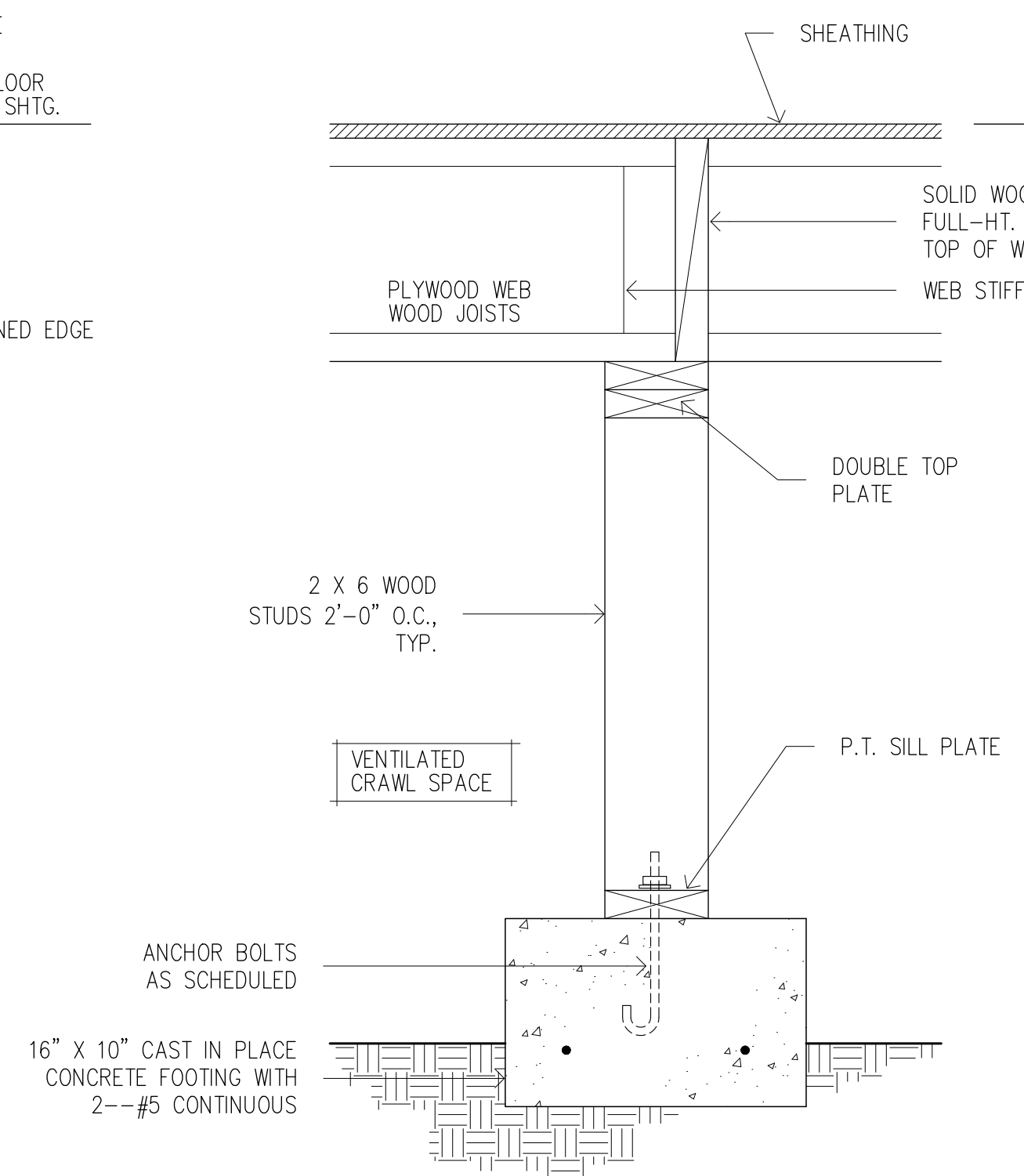

Typical Pony wall 5
SEE DTL. 5/A17 FOR ADDITIONAL INFORMATION

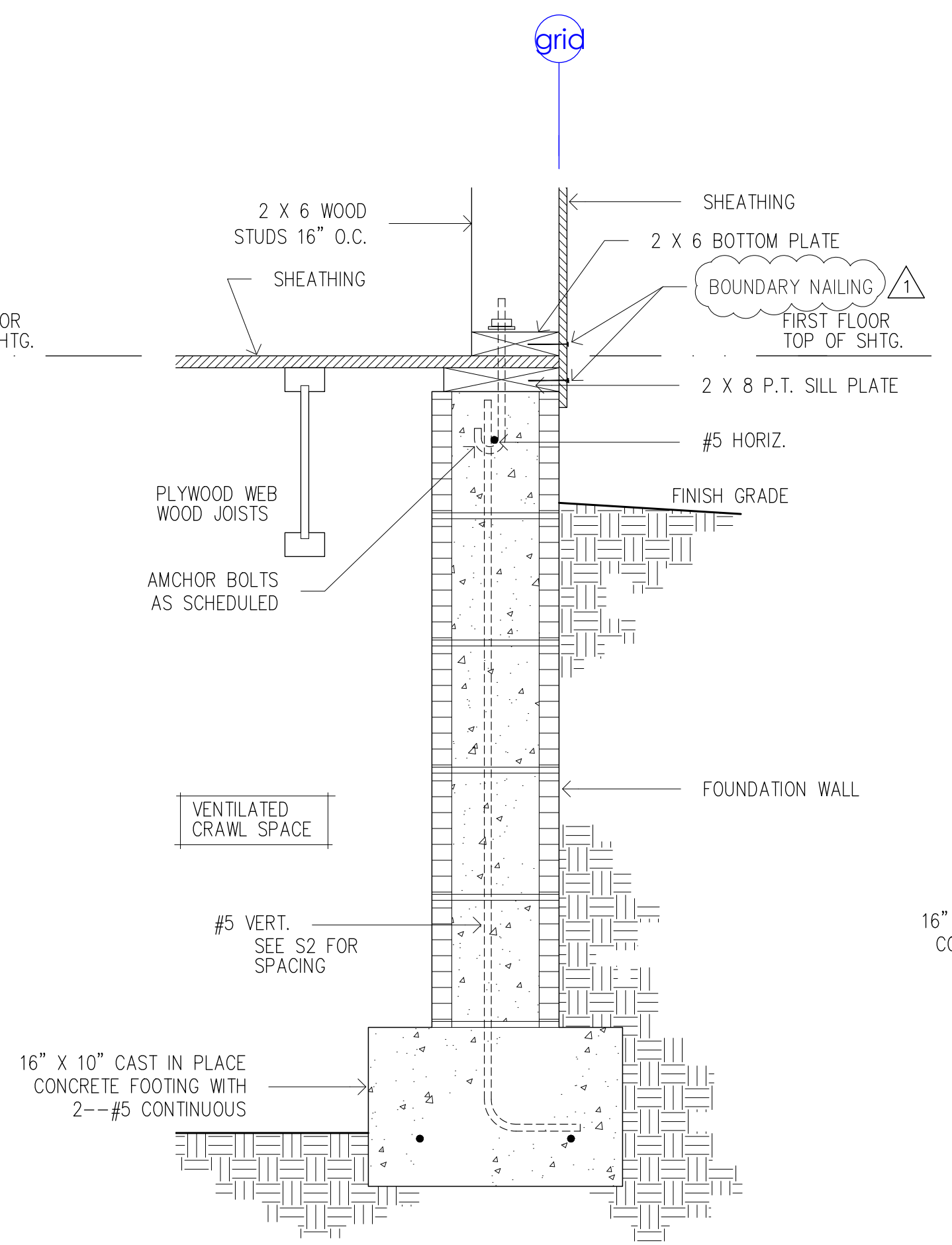

Typical Foundation wall 3
SEE DTL. 3/A17 FOR ADDITIONAL INFORMATION

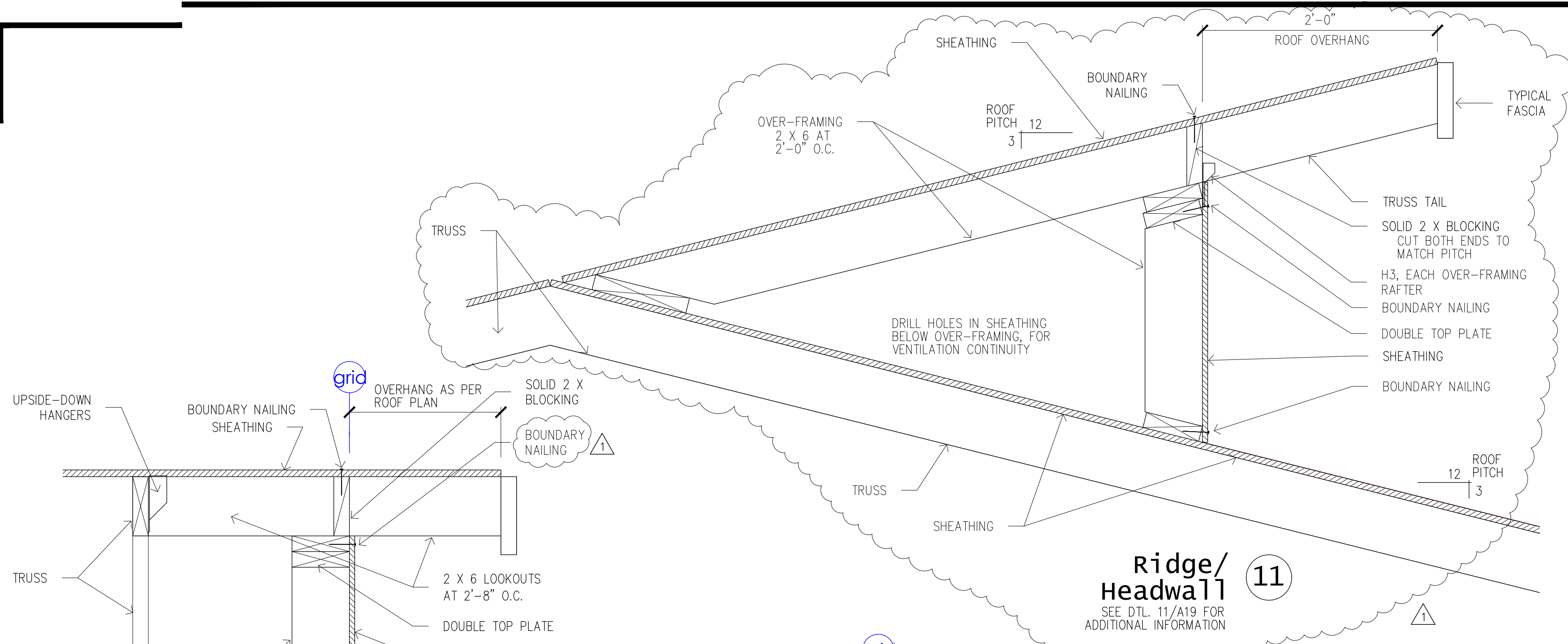

Ridge/Headwall (11)
SEE DTL. 11/A19 FOR ADDITIONAL INFORMATION

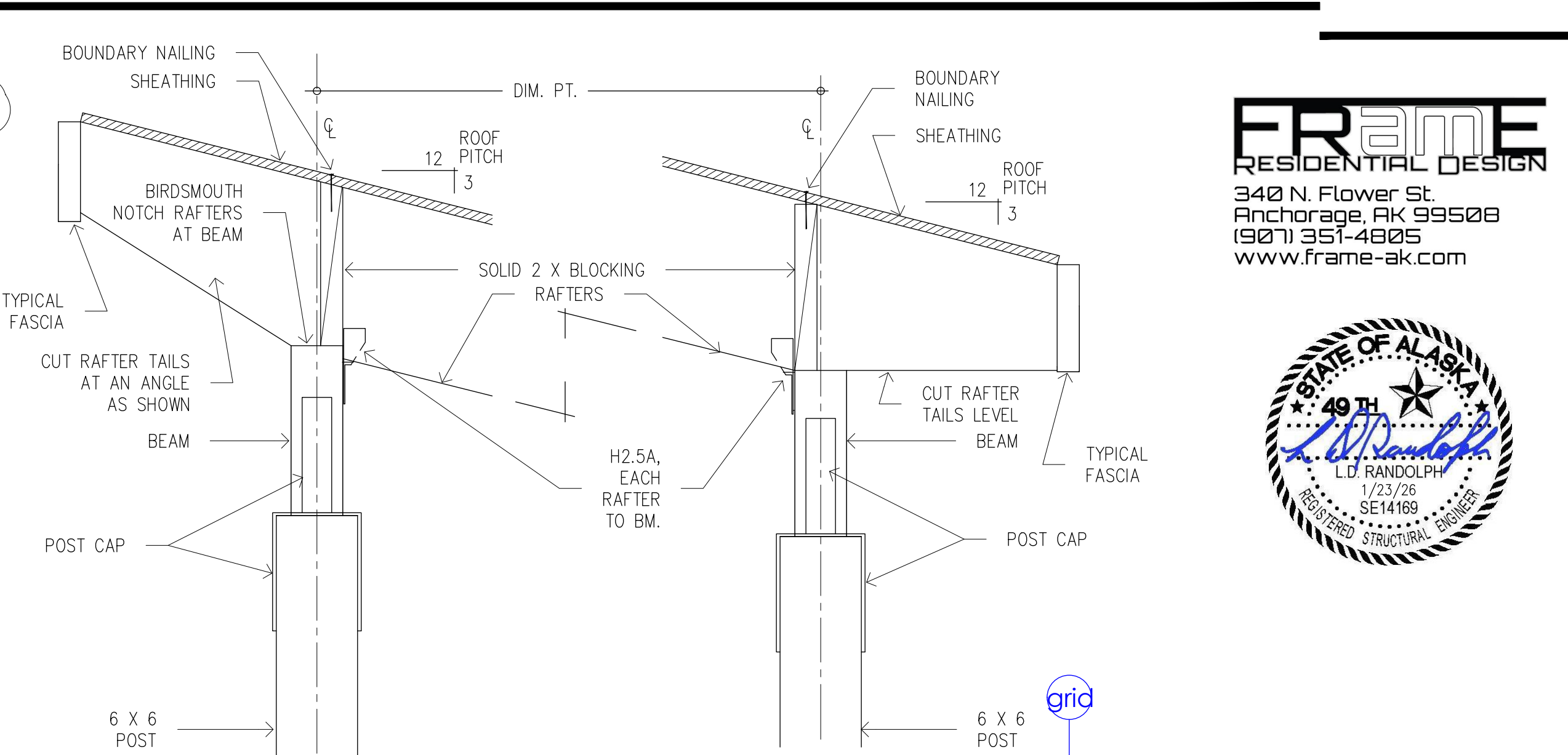

Back Porch Canopy at Unit #4 (4)
SEE DTL. 4/A17 FOR ADDITIONAL INFORMATION

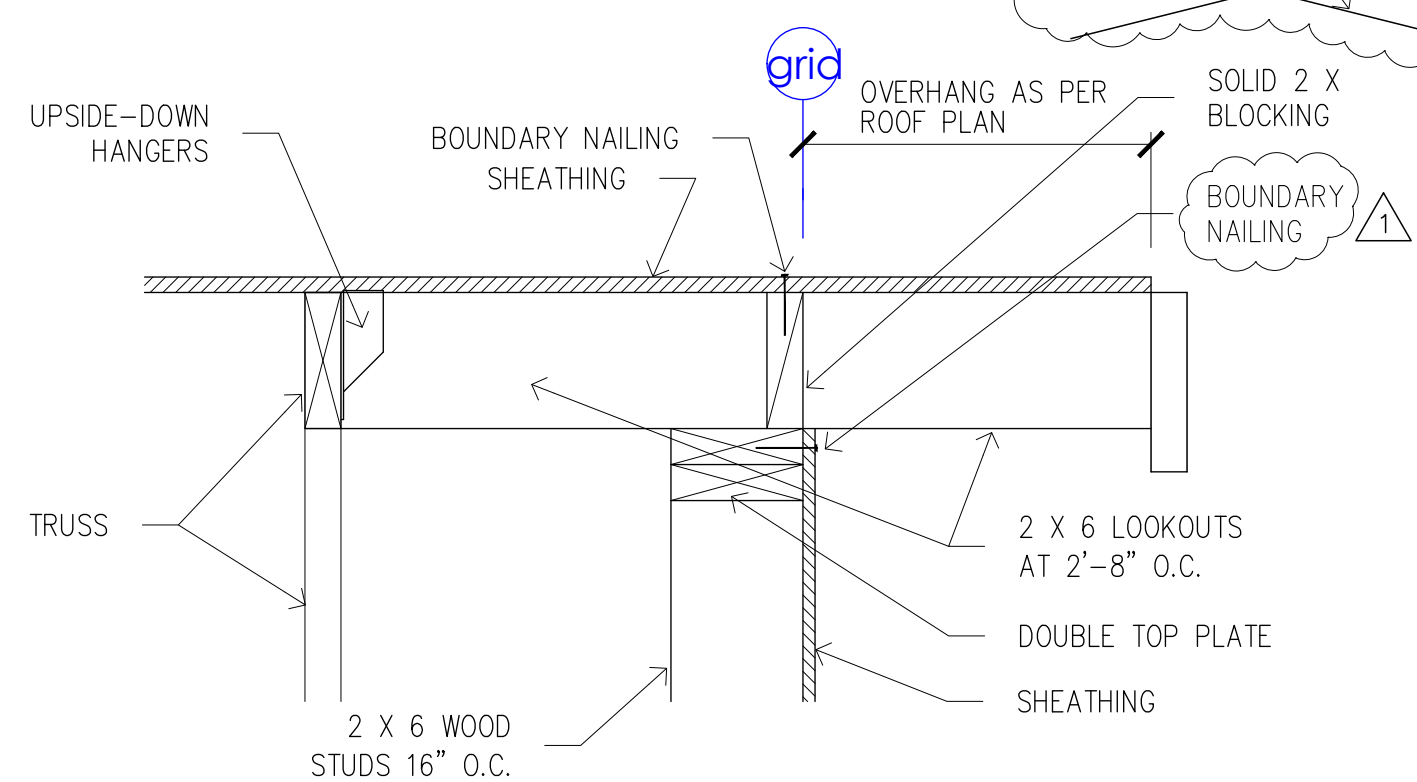

Typical Rake (10)
SEE DTL. 10/A19 FOR ADDITIONAL INFORMATION

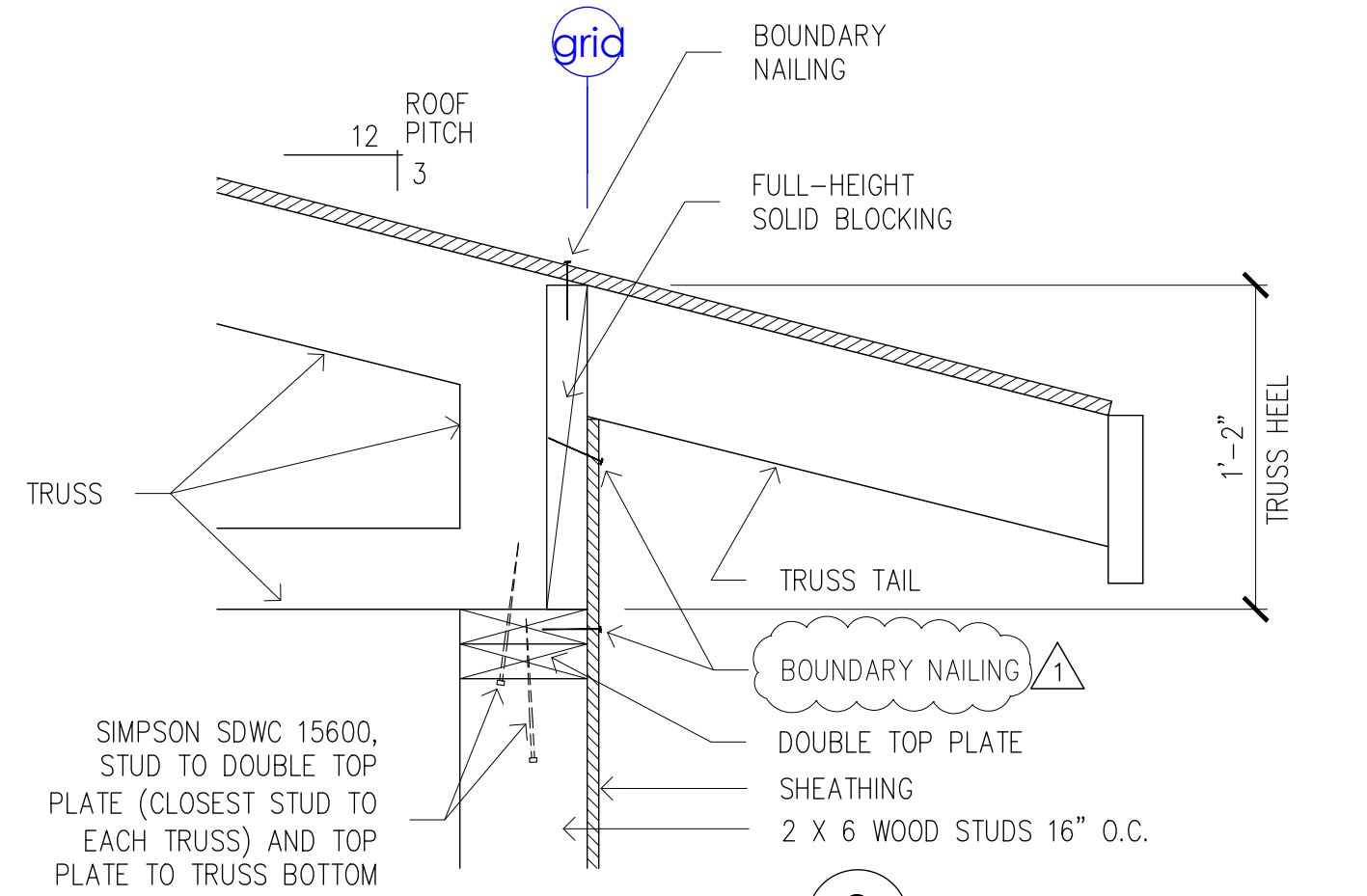

Eave (9)
SEE DTL. 9/A19 FOR ADDITIONAL INFORMATION

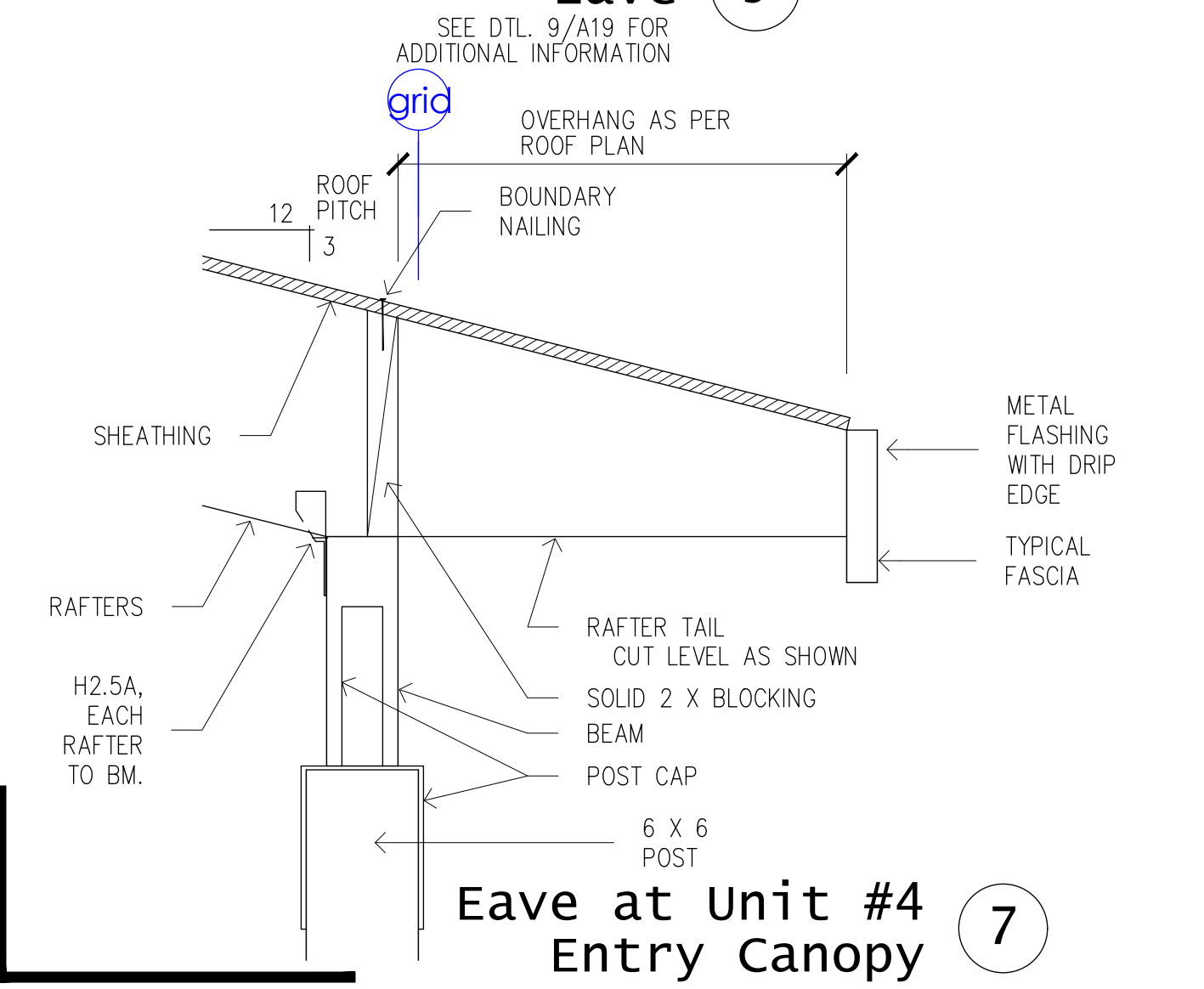

Eave at Unit #4 Entry Canopy (7)

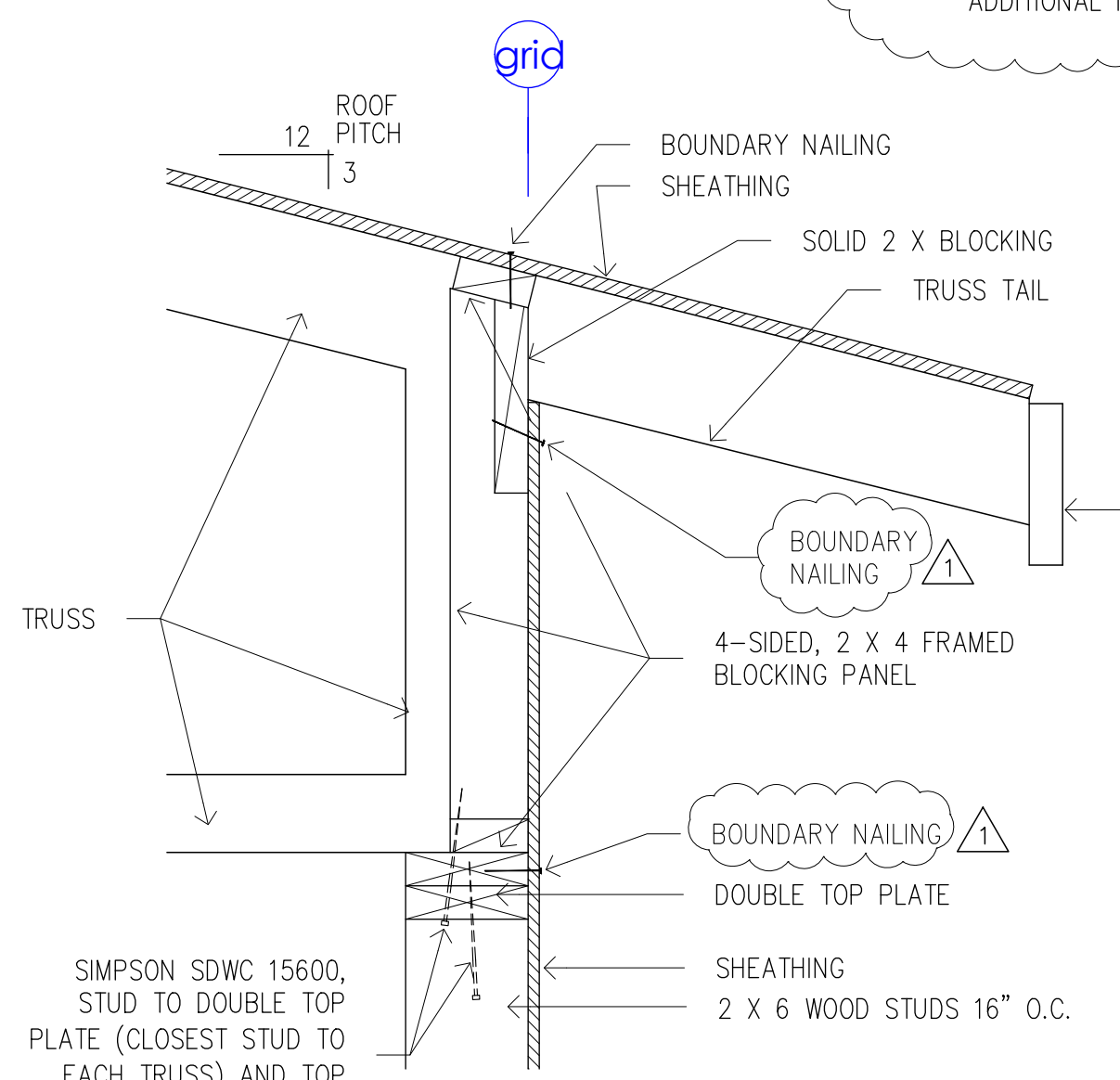

Eave (6)
SEE DTL. 6/A19 FOR ADDITIONAL INFORMATION

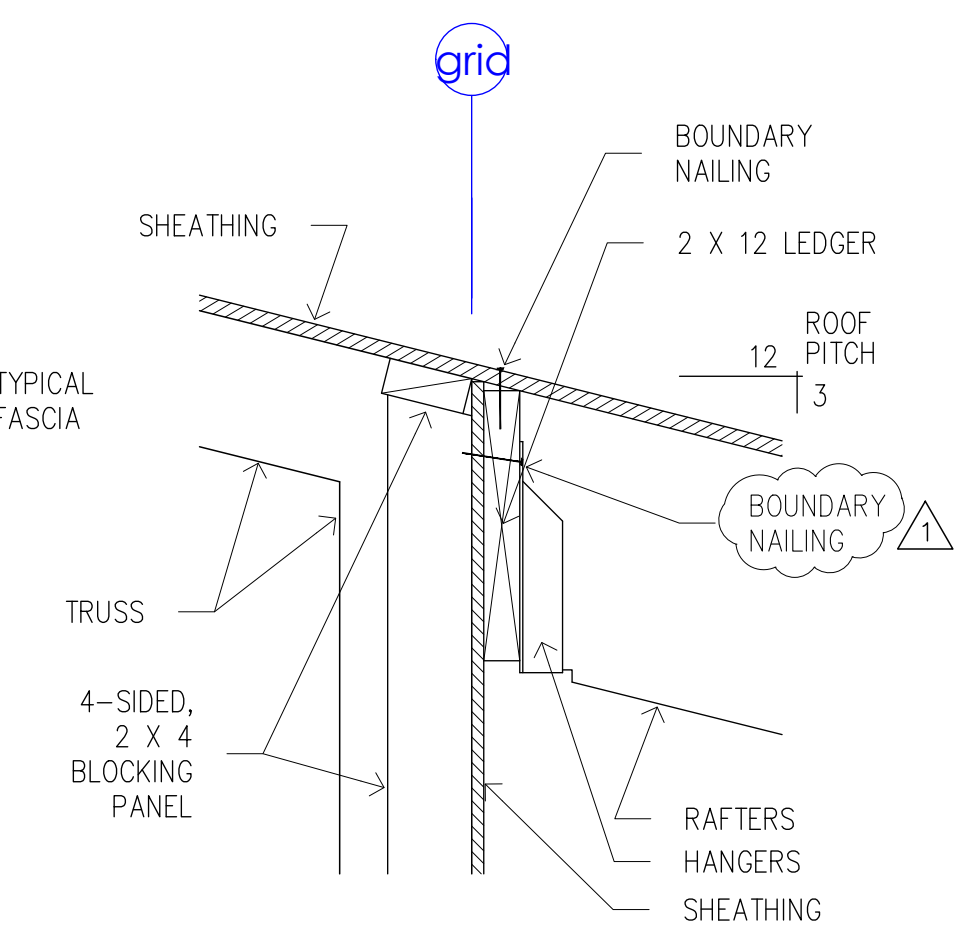

Roof Transition (5)
SEE DTL. 5/A19 FOR ADDITIONAL INFORMATION

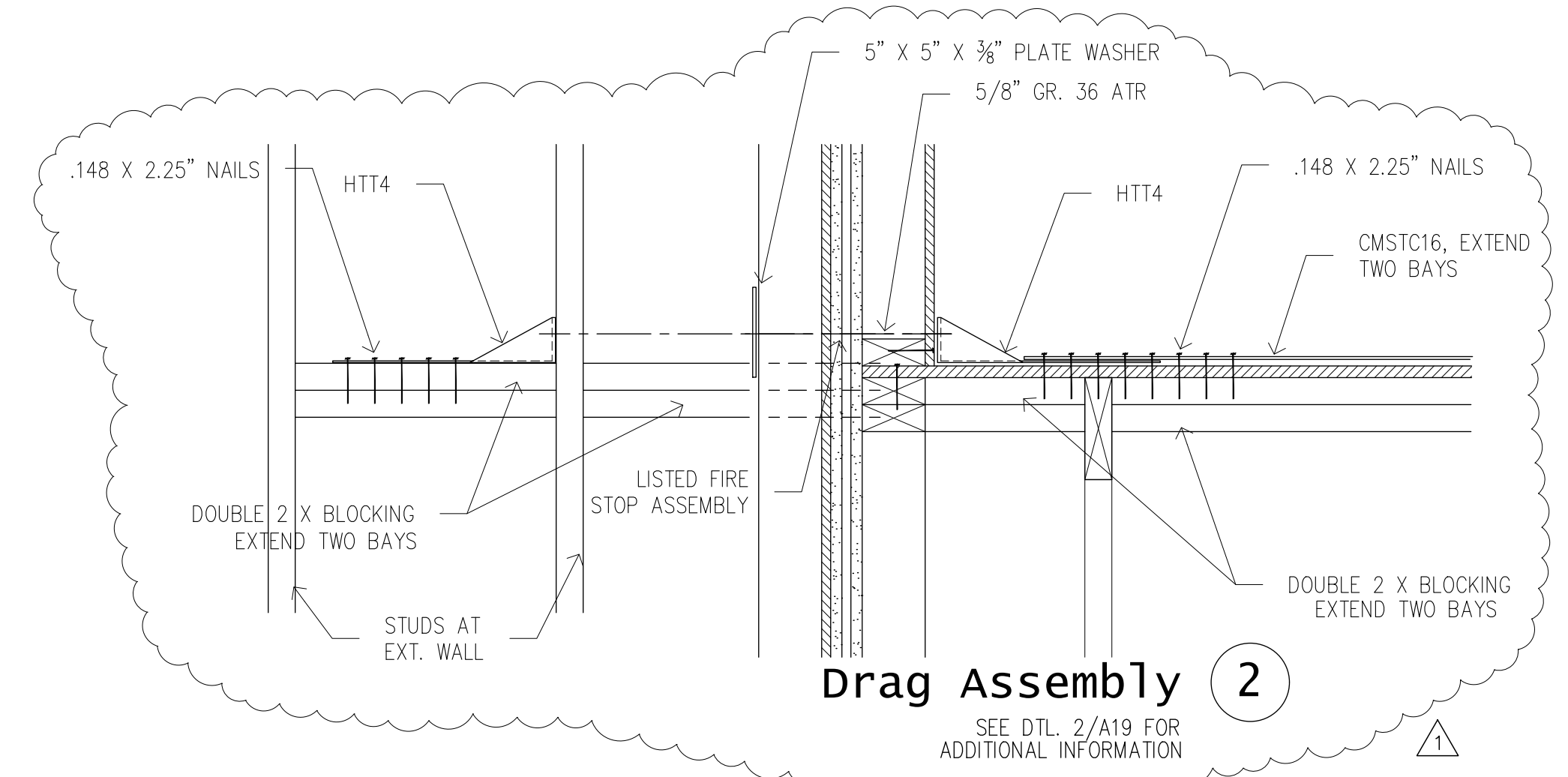

Drag Assembly (2)
SEE DTL. 2/A19 FOR ADDITIONAL INFORMATION

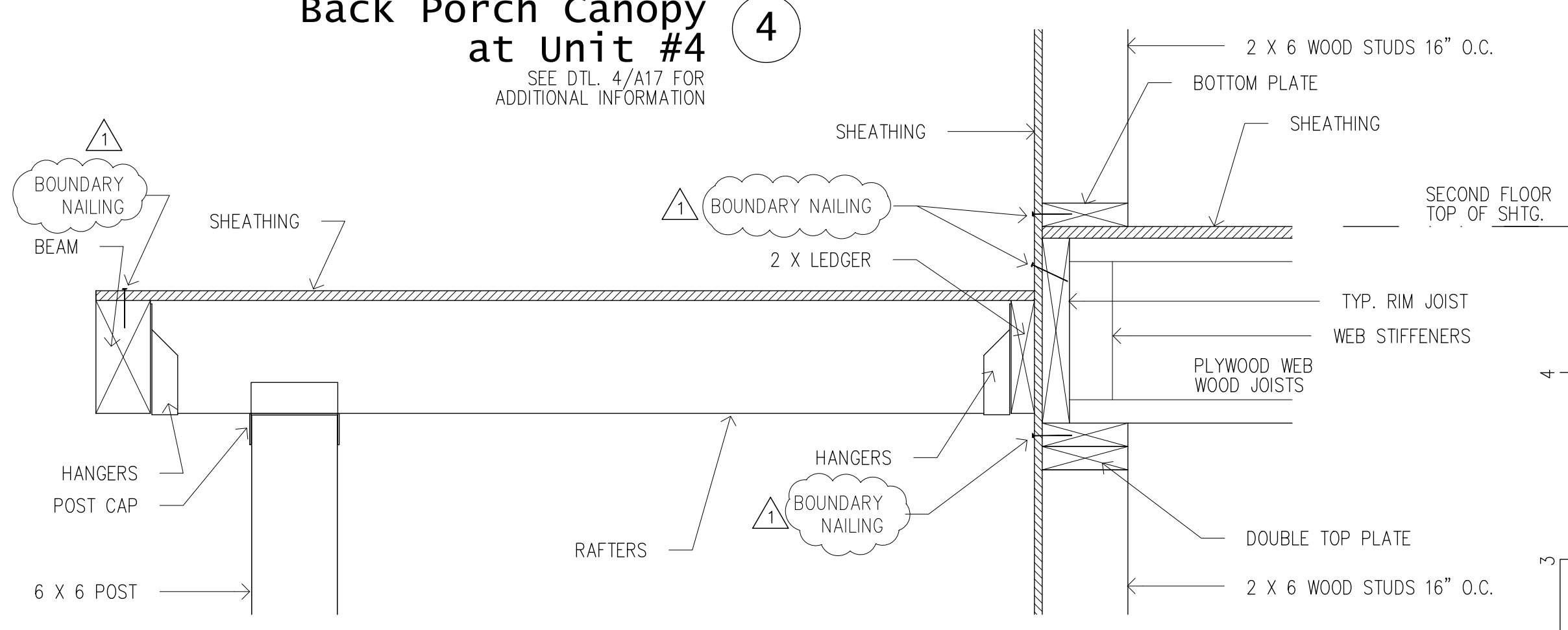

Back Porch Canopy Roof (3)
SEE DTL. 3/A19 FOR ADDITIONAL INFORMATION

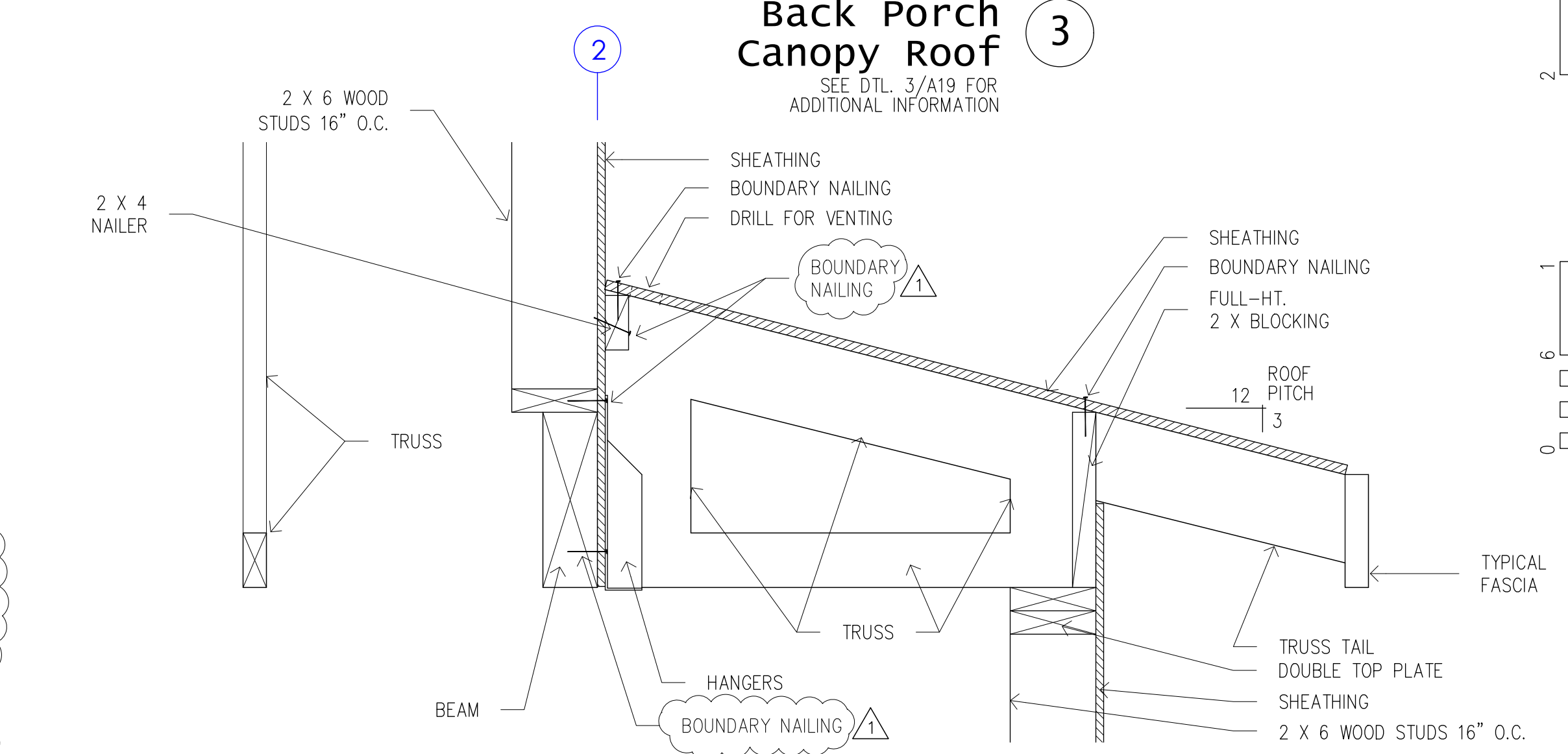

Eyebrow Truss at Bedroom Pop-Out (1)
SEE DTL. 1/A19 FOR ADDITIONAL INFORMATION